

MobiSet 4 Twin CAP 950



Contents

1	General	4
2	Scope of Delivery	5
3	Intended Use	6
4	Safety Instructions and General Guidelines	7
5	Installation and Connection	12
5.1	Installing and Connecting the Turntable	12
5.1.1	Required Tools and Equipment	12
5.1.2	Unpacking and Preparing	12
5.1.3	Selecting the Installation Location	13
5.1.4	Installing the Cable Gland and Mounting Plate	14
5.1.5	Possibilities of the Turntable Installation	16
5.1.6	Installing the Turntable	19
5.2	Installing and Connecting the CAP Converter	20
5.2.1	Selecting an Installation Location	20
5.2.2	Preparing the CAP Converter for Installation	22
5.2.3	Important Instructions for Installation	22
5.2.4	Installing the CAP Converter on a TV Set	23
5.2.5	Installing the CAP Converter	24
5.2.6	Laying the Cables and Connecting the Turntable	25
5.2.7	Connecting the CAP Converter	25
5.2.8	Functional Instructions for Connection to the On-board Power Supply	27
5.2.9	Connection Example for 12 V Battery Connection	27
6	Reception Range/Footprint	28
7	Dismantling for Servicing	29
7.1	Dismantling the Turntable	29
7.2	Address of the Service Centre	29
8	Polarisation Setting	30
9	Manually Lowering the Antenna to Park Position	30
9.1	Safety Instructions	30
9.2	Manual Lowering	31
10	Technical Data	32
10.1	Technical Data	32
10.2	Dimensions (in mm)	33
11	DEKAsyl MS Safety Data Sheet	34
12	DEKysyl MS Technical Data Sheet	41

13	Operating Instructions CAP 950	44
13.1	Safety Instructions and General Guidelines	45
13.2	Installing the CAP Converter	46
13.3	Change of Location	46
13.4	Operating the Turntable Using the External Push-button	47
13.4.1	Starting the Turntable	47
13.4.2	Moving the Turntable to the Park Position	47
13.4.3	Resetting the CAP System	47
13.5	Updating Software and Channel List	47
13.5.1	Updating the Channel List	47
13.5.2	Updating Software	47
13.6	LED Status Indicator on the CAP Converter/External Push-button	48
14	Waste Disposal	49
15	Declaration of Conformity	50

1 General

Dear Customer, Chère Cliente, Cher Client, Gentile cliente, Estimado cliente,

GB

You can obtain an English version of our mounting instructions from our representatives in your country¹⁾ or download one from our web site²⁾.

F

Vous pouvez obtenir un manuel d'installation en français chez notre représentant en votre pays¹⁾ ou le télécharger de notre site Web²⁾.

I

Lei può avere la versione italiana delle istruzioni di montaggio dalla nostra rappresentanza¹⁾ più vicina della sua città, oppure scaricarla dalla nostra web site²⁾.

E

Para obtener la versión española de nuestro manual de instalación, contacte nuestros representantes en su país¹⁾ o bajela de nuestra página de internet²⁾.

¹⁾ <https://www.kathrein.com/en/company/kathrein-worldwide/>

²⁾ <http://www.kathrein.de/en/sat>

Company address and accredited representative

KATHREIN-Werke KG
Anton-Kathrein-Straße 1 – 3
83022 Rosenheim, Germany

Anton Kathrein,
Personally liable Managing Director of
KATHREIN-Werke KG

2 Scope of Delivery



- ① Turntable with integral controls and GPS receiver
- ② Satellite dish, 75 cm
- ③ Twin LNB
- ④ CAP converter

The MobiSet 4 CAP 950 consists of:

- turntable ① complete with control electronics and GPS receiver, pre-assembled satellite dish ② and Twin LNB ③, automatic skew
- mounting plate
- complete cabling set:
 - 1 x master coaxial cable¹⁾, marked in red, for connection to the CAP converter²⁾
 - 1 x slave coaxial cable¹⁾, for connection to a second receiver or TV with an integrated receiver
 - 1 x power supply cable¹⁾
 - 2 x coaxial extension cables, 8 m each, F-type male connector to F-type male connector, 1 x marked in red
 - 1 x power supply extension cable, 10 m, incl. blade-type fuse 15 A, for connection to the on-board power supply
- roof duct with sealing gasket
- DEKAsyl MS adhesive sealant (100 ml tube)
- CAP converter ④ with a 12 V connection cable and LED/push-button cable
- 4 x wood screws 4.5 mm x 30 mm
- MobiSet 4 CAP 950 installation manual

¹⁾ fixed connection to the turntable

²⁾ In order to connect a TV to the CAP converter, you will need a coaxial cable *F-type female connector/F-Type female connector*, the length of which depends on the distance between the TV and the CAP converter. This cable is *not* included in the scope of delivery. For more information, see 13.2, p. 46

3 Intended Use

The MobiSet 4 CAP 950 is designed to receive digital TV and radio channels via satellite. The automatic positioner is intended to be used as a turntable for the Kathrein satellite dish.

The turntable can be used to receive digital TV and radio signals in the frequency range from 10.70 to 12.75 GHz; the antenna cannot receive terrestrial signals (e.g. DVB-T).

The MobiSet 4 CAP 950 offers a receiver-independent solution and can be used with any SAT compliant end device. The CAP converter takes over the communication and control of the system and converts signals received by the end device to CAP compliant signals. This way, it provides for the fully automatic alignment of the planar antenna to receive digital satellite signals.

The turntable is designed for use on stationary caravans or motor homes.

Any use other than that specified above will invalidate the warranty or guarantee.

The following circumstances result in the loss of all warranty and liability claims towards the manufacturer:

- improper installation
- use of non-specified mounting materials, which cannot guarantee the mechanical reliability of the antenna system
- Impermissible use, e.g. use of the planar antenna for storage
- structural changes or interference with the components and mounting accessories in the set, which could endanger both the mechanical and functional reliability
- improper or forcible opening of the components
- use of cleaners containing solvents, such as acetone, nitro-cellulose thinners, petrol, etc.
- failure to observe installation and safety instructions in this manual

4 Safety Instructions and General Guidelines



DANGER



Danger to life from electric shock when touching electrical installations!

- ▶ Maintain a minimum clearance of 1 m from all electrical devices.
 - ▶ Disconnect the turntable and all the units connected to it from the power supply during installation/repairs/dismantling.
 - ▶ Make sure that modifications to the electrical installations in the vehicle are only carried out by a specialist in vehicle electrics. Do not make any unauthorised changes to the turntable!
-



WARNING

Risk of severe injuries during installation/repairs/dismantling on the vehicle roof!

- ▶ Position the vehicle horizontally.
 - ▶ Wear stable shoes with non-slip soles.
- 
- ▶ Use a working platform.
 - ▶ Make sure that the person carrying out the installation or repair has a secure position to stand and hold on whilst working.
- 
- ▶ Make sure that the person carrying out the installation or repair does not suffer from vertigo and can move around safely on the roof of the caravan or motor home.
 - ▶ Make sure that the vehicle roof is sufficiently strong and stable. In case of doubt, contact a qualified specialist retailer or the manufacturer of your vehicle.
 - ▶ Make sure that there is nobody below the antenna inside the caravan/motor home during installation/repairs/dismantling.
 - ▶ Make sure that the roof and climbing aid are dry, clean and non-slip.
-



WARNING

Risk of severe injuries due to moving parts, especially risk of crushing!

- ▶ Make sure that no one, and in particular, no children, is in the immediate vicinity of the turntable and cannot touch any moving parts.
- 
- ▶ Disconnect the turntable and all the units connected to it from the power supply during installation/repairs/dismantling.
-



CAUTION

Trip hazard due to cables!

- ▶ Lay cables in such a way that no one can tread on them or trip over them.
-



WARNING

Risk of accidents due to collision of the antenna with objects!

An increase in the normal vehicle height due to the antenna not being lowered can lead to an increased risk of accidents. The driver bears sole responsibility for the condition of the superstructure and external fittings! If there is a storm warning, the turntable and the vehicle could be damaged.

- ▶ Follow instructions in the installation and operating manuals for the units used and for the external fittings and superstructures.
 - ▶ Before commencing a journey or if there is a storm warning, lower the antenna into horizontal position (park position).
 - ▶ Do not exceed the maximum permissible speed for vehicles of 130 km/h.
-



NOTICE

Risk of malfunction or material damage due to operation outside the permissible temperature range!

- ▶ Operate the turntable in an ambient temperature range from $-20\text{ }^{\circ}\text{C}$ to $+45\text{ }^{\circ}\text{C}$.
 - ▶ When selecting the installation and setup location, ensure that the receiver is sufficiently ventilated.
-

Proper Installation and Safety



The system may be installed only by qualified specialist personnel!

To prevent hazards during installation, operation or when driving on public highways, the instructions and information in this manual must be strictly adhered to. Proper installation and connection of the system are prerequisites for conformity with the corresponding standards.

This is documented in advance by the CE mark and the declaration of conformity in the appendix to this manual.

Essential information

A crucial safety factor is proper performance of installation and electrical connection work, and the specified alignment of the turntable in the direction of travel (park position), see Chapter 5, p. 12.

- ▶ Comply as precisely as possible with the installation conditions and steps described.

Adhesive sealant

The turntable is attached to the roof of the vehicle by adhesive and is secured by additional screws.

Note that the curing of the adhesive sealant is temperature-dependent. It reaches its full strength only after approximately 2 days.



NOTICE

Risk of material damage due to improper use of the adhesive sealant!

- ▶ During installation work, comply strictly with the processing and safety instructions for the adhesive sealant (DEKAsyl MS adhesive sealant safety data sheet and DEKAsyl MS adhesive sealant technical data sheet).

Road Traffic Licensing Regulations (StVZO)

The applicable regulations of the German StVZO must be observed in respect of fixed installation of the turntable on a vehicle which is driven on public highways. In particular, Articles 19/2; 30 C; 32 (2) and EC directive 74/483 EEC are applicable.

Briefly, they state that no endorsement of the vehicle documentation is required unless the antenna unit causes the height of the laden vehicle to exceed 2 m, or the antenna unit projects beyond the outer lateral outline of the vehicle. The maximum permissible height of 4 m for the vehicle and antenna unit must not be exceeded.

Cables



WARNING

Risk of fire!

If the cables are tied with a wire or the like, it could cause fire.

- ▶ Remove the wire or the like.
-



CAUTION

Trip hazard due to cables!

- ▶ Lay cables in such a way that no one can tread on them or trip over them.
-



NOTICE

Risk of parasitic induction or interference emissions!

An inappropriate cable or an extension cable can cause parasitic induction or interference emissions, thus reducing the picture quality.

- ▶ When extending the antenna cable, use a 75 Ω coaxial cable with a screening factor of at least 75 dB.
-



NOTICE

Risk of material damage due to reversed polarity!

When connecting the power cables, reversed polarity can lead to thermal overload and damage to components when the equipment is powered up.

- ▶ When connecting the power cables (CAP converter and turntable) to the vehicle electrical system, make sure that the poles are not reversed.
-

Supply Voltage, Fusing



WARNING

Risk of severe injuries due to cable fire!

If you remove or bypass the fuse in the cable, it can cause cable fire.

- ▶ Do not remove or bypass the fuse in the cable.
-



NOTICE

Risk of material damage due to the absence of a blade fuse in the cable!

- ▶ Protect the positive wire (red) of the power supply cable by using a 15 A blade fuse.
 - ▶ The fuse must be installed by a specialist.
 - ▶ If the fuse is blown, replace it by a fuse of the same rating (15 A).
 - ▶ Eliminate the cause of the fault.
-

To ensure a reliable function of the connection/control unit:

- ▶ Operate the system from your vehicle's battery (12 V) or a suitable power supply unit. The power supply unit must ensure a stable output voltage of 12 V, a continuous current of 11 A and 15 A (300 ms) surge current. The short-time power consumption is up to a maximum of 12 A.
- ▶ Connect the power supply cable directly to the battery.

Using the cable core marked *Ignition*, the power supply cable is connected to the ignition current circuit. This way, the turntable has a function for automatic lowering of the antenna. The lowering takes place as soon as the vehicle ignition circuit is turned on.

- ▶ When connecting the control unit to the on-board power supply, make sure that the *12 V*, *Earth* and *Ignition* wires cannot be disconnected by intermediate switches, as this could deactivate the automatic lowering function.

The antenna is lowered within 5 seconds of the ignition being switched on, even if the CAP converter is switched off.

The control unit is lowered immediately. Lowering the antenna after the ignition is switched on can take up to 30 seconds and it only functions if the turntable is connected to a 12 V power supply and to the ignition.

Checks before Commencing a Journey

- Before commencing a journey, always lower the antenna into the horizontal position (park position).
- If the antenna has collided with a fixed or movable object, check if the system is still securely attached.
- As the antenna is subjected to vibration loads during driving, check at regular intervals, depending on the frequency of driving, whether the system is still securely attached and tighten any parts that have worked loose.
- Do not exceed the maximum permissible speed of 130 km/h for vehicles with a receiver unit mounted on the roof.
- Lower the antenna if it will not be used for a long period. This makes the securing bolts more difficult to access (protection against theft).

Antenna in the Park Position whilst Driving

Always lower the antenna into the horizontal position (park position) whilst driving. To remind yourself of this, place the sticker from the supplementary sheet *CAP 950 Lowering the antenna while driving* in the visual range of your vehicle ignition switch.



Satellite Configuration in the CAP Converter



Important Note!

By means of a CAP converter, you can directly control 4 satellite positions with the help of a connected satellite receiver or a TV³⁾. In order to do so, the sequence of the satellite positions in the TV/ receiver must correspond to the sequence of the satellite positions in the CAP converter.

The CAP converter has the following default standard settings for satellite positions:

- Satellite 1: Astra 19.2°E
- Satellite 2: Hotbird 13°E
- Satellite 3: Astra 23.5°E
- Satellite 4: Astra 28.2°E

Setting the Satellite Position in the CAP Converter

The satellite positions in the CAP converter can be changed as follows:

- Using the free smartphone/tablet CAPcontrol app (available for Android and iOS)
 - ▶ To change the satellite position, go to **Settings** ▶ **Satellite selection** in the app.
 - To use the app, you will either need a LAN connection to the router or a wireless USB adapter UFZ 131¹⁾ with a wireless hotspot function.
- Using the external operating unit²⁾
 - ▶ To change the satellite position, press buttons to set the values.
- Using a software update of the xml file with satellites created on the computer by means of a USB stick. Ready-made *config.xml* files are available free of charge at www.kathrein.de/sat.
 1. On a USB stick, create a *kathrein* folder with a *capconverter* subfolder. (Use lower case letters for folder names!)
 2. Copy the *config.xml* file to the *capconverter* subfolder.
 3. Connect the USB to the active CAP converter.
 - ⇒ The *config.xml* file is installed automatically.
 - ⇒ During the installation, the LED is lit (yellow). After the successful installation, the LED is lit green and then yellow for 1 second, respectively.
 - ⇒ If the installation failed, the LED is lit red and then yellow for 1 second, respectively. Check the folder structure and make sure that the folder names are spelled in lower case letters.

For more information about setting the satellite positions of your receiver units, see the user manuals or call the hotline of the corresponding manufacturers.

^{1) 2)} available as accessories

³⁾ TV with a built-in satellite receiver

5 Installation and Connection

5.1 Installing and Connecting the Turntable

5.1.1 Required Tools and Equipment

- Circular cutter, Ø 38 mm
- Flat-bladed screwdriver for M5 screws
- Power drill
- The following screws, depending on the roof structure:
 - galvanised round head screws, Ø 5 mm, sheet metal screws D 7981 or
 - round head screws D 7985 with washers and nuts
- Twist drill, Ø 2.5 or 5.5 mm
- Round file and/or emery paper
- Cleaning agent
- Open-ended or ring spanners 10 and 11 mm across flats
- Knife
- Cross-head screwdriver for M3 and M5 screws
- Torque wrench capacity 6 to 11 Nm
- Hexagon socket key, 5 mm
- Two wooden beams for supporting the turntable

5.1.2 Unpacking and Preparing



WARNING

Risk of injury due to the heavy weight of the package!

The turntable together with the parabolic reflector weighs close to 20 kg.

- ▶ If necessary, please seek help from a second person when unpacking and installing the turntable.



NOTICE

Risk of material damage during transportation!

- ▶ Never pick up or carry the turntable by the planar antenna.

Unpacking the Turntable

1. Pull the turntable out of the packaging as shown in the illustration below.
2. Remove the packing pieces from the turntable ① before transporting it to the roof of the vehicle.
3. Loosen the 6 fastening screws (spanner size: 10 mm) which attach the turntable to the mounting plate.
4. Carefully lift the turntable off the mounting plate and place it onto the two prepared wooden supports. When doing this, make sure that the cables are not crushed where they emerge from the underside of the turntable.

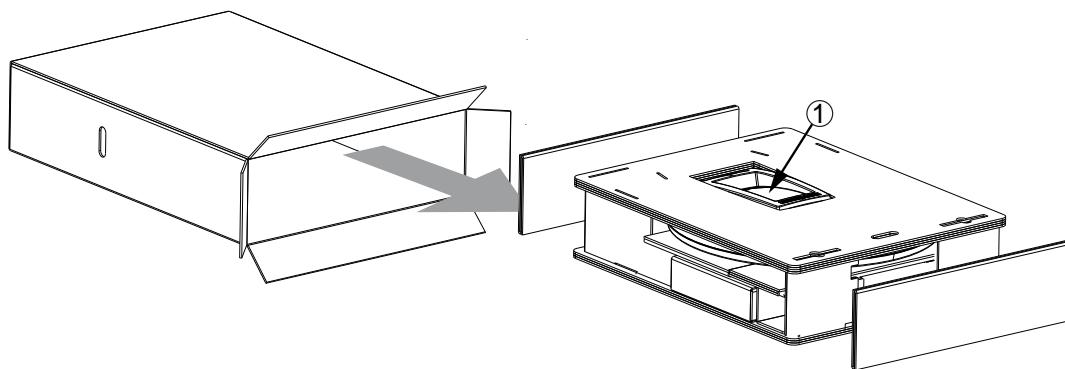

Tip

Retain the original packaging, because if it is necessary to send the unit for repair, transport damage cannot be ruled out and the manufacturer accepts no liability for possible damage.

5.1.3 Selecting the Installation Location

Essentially, the cable lengths and components that are supplied allow you a free choice of installation location on your caravan or motor home.

When selecting the installation location, take note of the following points:

- ▶ Before installation, find out whether the operating manual for your vehicle permits the fitting of non-vehicle-specific parts or what requirements need to be met in order to do so.
- ▶ For direct satellite reception, there should be no obstructions between the antenna and the satellite. Therefore, make sure that the antenna is not shadowed by roof attachments such as luggage racks, air conditioning units, solar panels, etc.
- ▶ The problem of shadowing applies also when selecting a parking place for your vehicle. For interference-free satellite reception, the antenna needs a free view to the south at an angle of between 15° and 55° (depending on location) to the horizontal.
- ▶ When selecting the installation location, take into account the range of movement of the turntable, see Chapter 10, p. 32. There must not be any attachments on the roof that would obstruct this range of movement (risk of collision). To be on the safe side, keep slightly more than the required area free. This allows for an easier installation and any subsequent dismantling.
- ▶ Choose an installation position on the roof that is as horizontal as possible or only slightly sloping, depending on the location of the vehicle, since roof inclinations greater than 5° may lead to problems when searching for the satellite.
- ▶ To ensure secure adhesion, the height difference of the roof curve must not be more than 1 cm over a length of 2 m, as otherwise the gap between the roof and the mounting plate would be too great to be filled by the adhesive sealant.
- ▶ As the vehicle is constantly subjected to vibration loads during travel, the roof below the antenna unit is also subject to significant loads. Please note, given the nature and capacity of your vehicle roof, that the weight of the antenna unit is approx. 19 kg, see the operating manual for the vehicle. In case of doubt, consult a qualified specialist dealer or your vehicle's manufacturer.
- ▶ The roof duct provides a watertight seal through which the three cables (2 x coaxial cables, one power supply cable) are fed into the interior of the vehicle directly underneath the turntable. If you prefer a different method of laying the cables, you can run them out from the rear of the turntable via the channel provided in the mounting plate. The cables must then be run along the roof of the vehicle in a protective cable duct and through a separate roof duct HDZ 100 (neither of them are included in the scope of delivery).
- ▶ The HDZ 100 roof duct is available as an accessory under part number 20410032 from specialist dealers.



NOTICE

Risk of malfunction or material damage, in particular due to the absence of a blade fuse in the cable!

- ▶ Protect the positive wire (red) of the power supply cable by using a 15 A blade fuse.
 - ▶ The fuse must be installed by a specialist.
 - ▶ If the fuse is blown, replace it by a fuse of the same rating (15 A).
 - ▶ Eliminate the cause of the fault.
-

Roof attachments may be mounted within the hatched area.

Turntable movement range with antenna, viewed from above onto the vehicle roof.

The safety clearances should be maintained from the roof attachments (e.g. due to a build-up of ice)

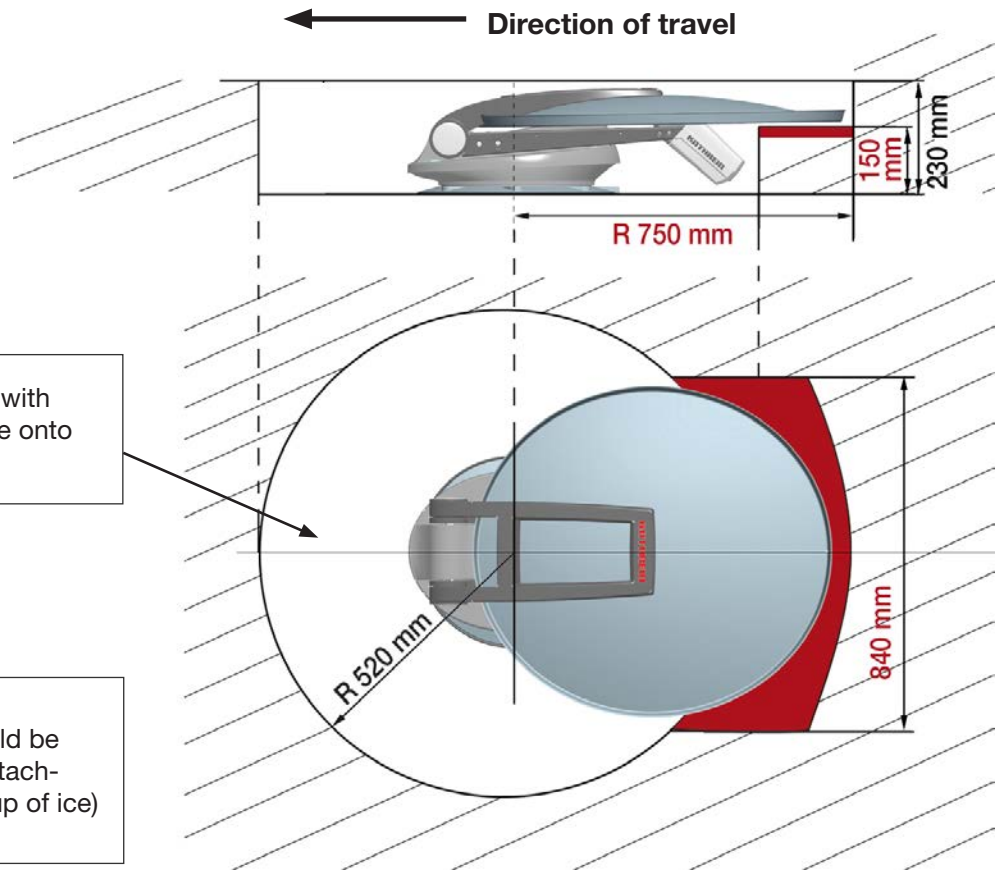

5.1.4 Installing the Cable Gland and Mounting Plate

Tip If you have previously used a Kathrein HDM 140/141 jointed tripod mast or another mast with a diameter of 34 mm, you can continue using the existing through hole in the roof.

Fig. A

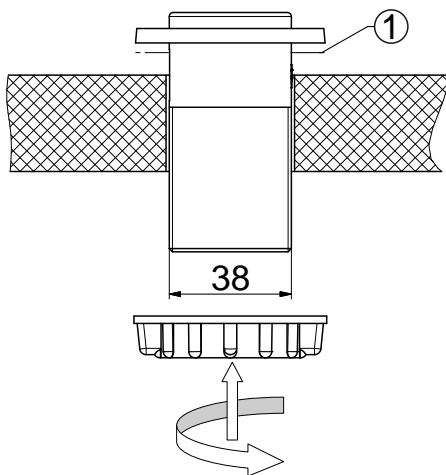
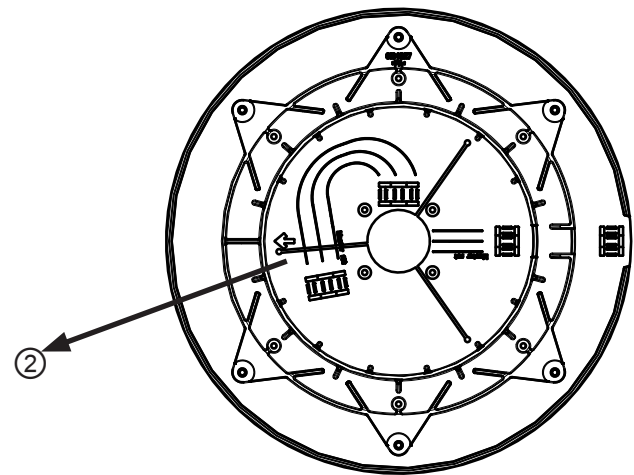

Fig. B



① Adhesive

② Arrow in the direction of travel

1. In the centre of the intended position of the turntable, drill the opening for the cable gland with a circular cutter of $\varnothing 38$ mm .
2. Deburr the hole with a round file or emery paper.

3. Provisionally insert the roof duct into the drilled hole (Fig. A).
4. Place the mounting plate on the roof of the vehicle such that the centre hole is positioned centrally to the cable gland. The **arrow symbol** ③ must be visible from above and point forwards in the **direction of travel** of the vehicle (Fig. B).
5. Mark the positions of the six fastening holes on the vehicle roof in a pitch circle.

Tip The size of the holes and the choice of fastening screws to be used (not included in the scope of delivery) depend on the type and thickness of the materials used in the roof structure. If the roof panelling (plastic roofs) is sufficiently strong, it is recommended to always use round head screws, plain washers and self-locking nuts to secure the glued mounting plate.

6. If the roof panel material is very thin and does not provide adequate holding power within the insulation material, make through holes of $\varnothing 5.5$ mm into the interior of the vehicle and use galvanised M5 round head screws of sufficient length. Make sure that you use a sufficiently strong support that can withstand the bolt tensile forces (large plain washer or a complete reinforcing plate).

Fig. C

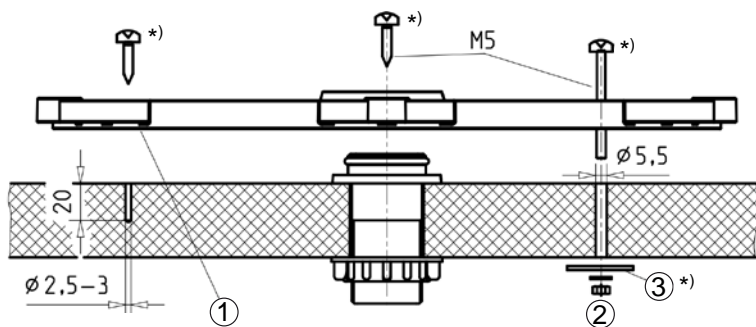

- ① adhesive area between the grooves
- ② alternative roof fastening
- ③ washer*)

*) Not included in the scope of delivery

7. Create the holes necessary to secure the mounting plate (Fig. C).
8. In addition to the screw connection, the mounting plate and roof duct must be bonded to the roof with adhesive and sealed. This is done using the DEKAsyl MS adhesive sealant supplied, which is ideally suited for this purpose due to its broad range of adhesion. Please note the following points:
 - **Before you start working with the DEKAsyl MS adhesive sealant, it is essential that you have carefully read through the safety data sheet for the DEKAsyl MS adhesive sealant and the technical data sheet in this installation manual!**
 - The prerequisite for good adhesive properties is a clean, dry and grease-free substrate. Therefore, clean the roof surface with a suitable cleaning agent within a circumference of 17 cm around the drilled hole and allow the surface to dry thoroughly.
 - If the surface is painted, ensure that the paint finish is sufficiently well bonded to the substrate.
 - If the coat of paint is already loose or peeling, remove it down to a stable layer in the area to which the adhesive will bond. If you have any doubts concerning the adhesive properties, consult a paint and lacquer specialist or the manufacturer of your vehicle.
9. The procedure for gluing the mounting plate is as follows:

Fig. D

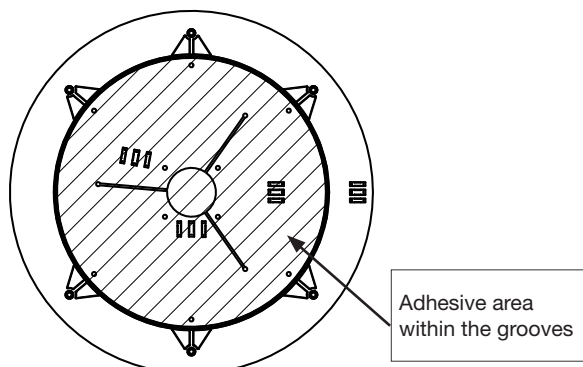

- Ensure before starting adhesive work that the processing temperature of materials to be glued and the adhesive sealant is between +5 °C and +35 °C. Prepare all necessary fastening elements and tools.
- Prepare the tube of adhesive sealant in accordance with the instructions enclosed with the tube.
- Remove the roof duct (Fig. A) and apply the adhesive sealant evenly to the underside of the roof duct flange.
- Place the roof duct in the drilled hole and press it firmly against the roof of the vehicle.
- Apply the adhesive sealant evenly to the underside of the mounting plate, completely covering the area within the circular groove (Fig. D). This area of the vehicle roof must be completely coated with adhesive in order to achieve the necessary bonding force.
- Place the mounting plate onto the roof of the vehicle, as you did previously when marking out the drilled holes. Make sure that the arrow on the mounting plate points forwards in the direction of travel of the vehicle and that the fastening holes are perfectly aligned with the prepared holes in the roof.
- Fasten the mounting plate in place with the prepared screws, evenly tightening six screws across the diagonals.



NOTICE

Risk of material damage due to applying too much force when tightening the screws!

The adhesive sealant used is capable of filling small gaps caused by the curvature of the vehicle roof. If you apply too much force when tightening the screws, the mounting plate could be bent.

- ▶ Tighten the screws carefully.

- Use a clean colourless cloth to remove any adhesive sealant that leaks out at the sides. Pay attention to the following:
 - ~ Do not use any cleaning agents or thinners containing solvents, as this could damage the adhesive sealant applied under the mounting plate.
 - ~ It is recommended to soak the cloth in acetone or MEK. Apply the cloth soaked in acetone or MEK to an inconspicuous area to make sure that it does not adversely affect or damage the surface.
 - ~ Use only cleansing paste and water to clean your hands.
- Secure the cable gland from inside the vehicle by tightening the ribbed nut supplied (Fig. A).
- Note that the curing of the adhesive sealant depends on the ambient temperature and the humidity. The final strength is reached only after approx. 2 days. However, this need not restrict further installation work, since the mounting plate is held in place by the tightened screws.

5.1.5 Possibilities of the Turntable Installation

Variant with Cable Gland underneath the Turntable

1. Lay the cables supplied with the turntable (2 × coax cables and 1 × power supply cable) into the mounting plate as indicated by the markings on the mounting plate (see Fig. E1).
2. Feed the remaining lengths of cable through the roof gland into the interior of the motor home / caravan.
3. Lift up the turntable and place it carefully on the mounting plate facing in the direction of travel (see Fig. E2). Make sure not to step on the plug connector and not to kink / crush the cables.
4. Align the through holes on the turntable with the threaded holes on the mounting plate.
5. Allow the turntable to rest on the front edge of the mounting plate.
6. Keep the turntable supported at an angle (see Fig. E1) and insert a suitable piece of wood underneath it.
7. Lay and connect the turntable cables in the mounting plate as indicated on the mounting plate, see Fig. E1. Take particular care that the two master coaxial cables, marked red, are connected to each other.
8. Tighten the coaxial cable plugs finger-tight, using no tools.
9. Tighten the coaxial cable plugs lightly using an open-ended 11 AF spanner.
10. Lower the turntable back on to the mounting plate. Make sure that the cables are fed through the cable gland and are not snagged.
11. Apply a little adhesive sealant to the six threaded holes in the mounting plate and screw the fastening screws into the thread. Tighten the screws to a torque of 6 Nm.
12. To prevent water vapour from inside the vehicle reaching the turntable through the roof gland, thread the three cables

through the sealing gasket supplied (see Fig. E2), close the gasket and insert it into the roof gland until it reaches the stop. Make sure that no tensile load is acting downwards on the sealing gasket as this can cause it to fall out in the course of time.

Fig. E1

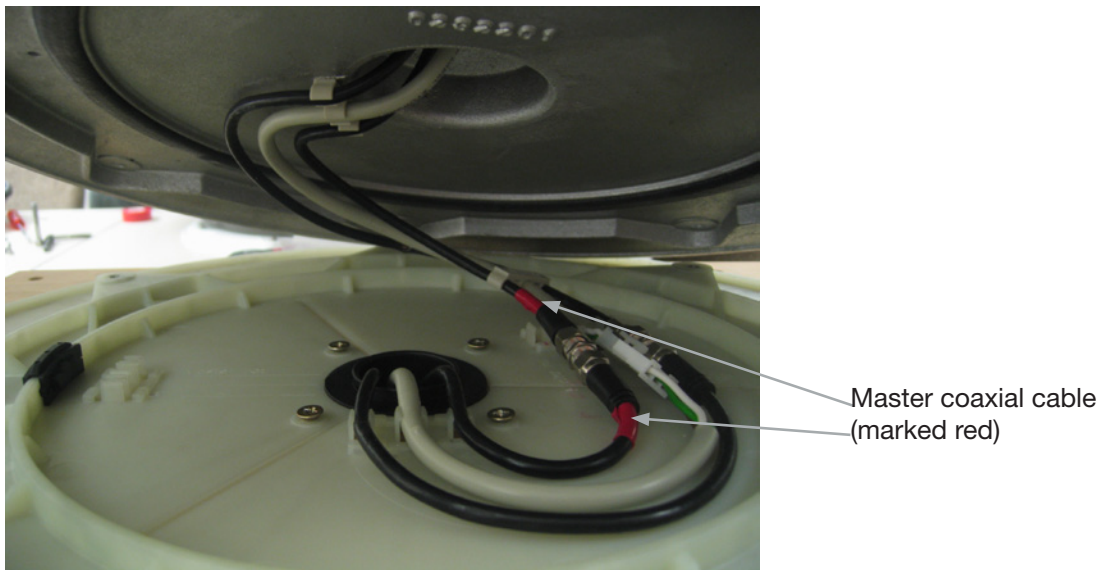
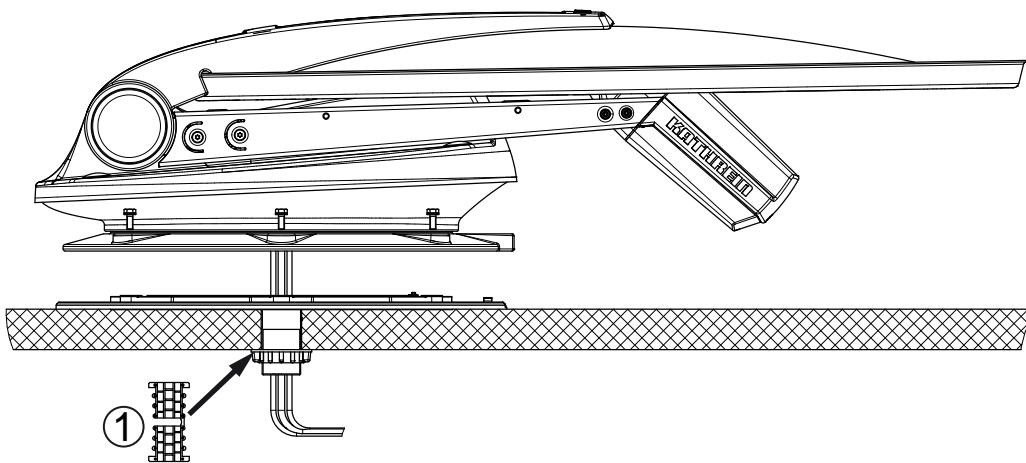

Fig. E2



① = sealing gasket

Variant with External Cable Gland

1. Lay the cables supplied with the turntable (2 × coax cables and 1 x power supply cable) into the mounting plate as indicated by the markings on the mounting plate, see Fig. F1.
2. Feed the remaining lengths of cable through a cable duct and a cable gland⁹⁾ into the interior of the motor home / caravan.
3. Lift up the turntable and place it carefully on the mounting plate facing in the direction of travel, see Fig. F2. Make sure not to step on the plug connectors and not to kink / crush the cables.
4. Align the through holes on the turntable with the threaded holes on the mounting plate.
5. Allow the turntable to rest on the front edge of the mounting plate.
6. Keep the turntable supported at an angle (see Fig. F1) and insert a suitable piece of wood underneath it.

7. Lay and connect the turntable cables on the mounting plate as indicated on the mounting plate, see Fig. F1. Make sure that the cables are not crossed over and that they are taut so that they cannot be crushed. Take particular care that the two master coaxial cables, marked red, are connected to each other.



NOTICE

Risk of material damage due to pulling the cables from the turntable!

- ▶ Do not try to pull the cables from the unit.

8. Tighten the coaxial cable plugs finger-tight, using no tools.
9. Tighten the coaxial cable plugs lightly using an open-ended 11 AF spanner.
10. Carefully lower the turntable back on to the mounting plate. Make sure that the through holes on the turntable are perfectly aligned with the threaded holes on the mounting plate.
11. Apply a little adhesive sealant to the six threaded holes in the mounting plate and screw the fastening screws into the thread. Tighten the screws to a torque of 6 Nm.
12. Run the connecting cables through the waterproof HDZ 100¹⁾ roof gland into the interior of the vehicle. In doing so, make sure that the cables are not crushed, kinked or damaged.

¹⁾ Not included in the scope of delivery! The HDZ 100 roof gland is available as an accessory under part number 20410032 from specialist dealers.

Fig. F1

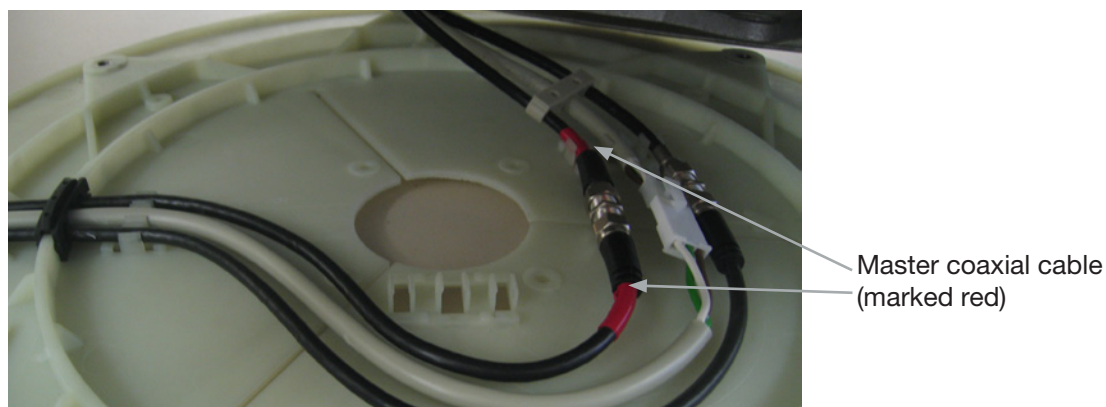
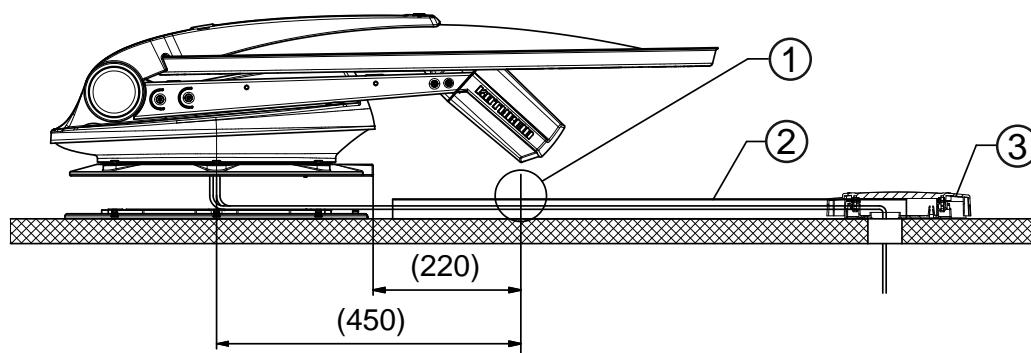

Fig. F2



- ① When using a cable duct as a direct extension of the cable exit from the CAP, its height must not exceed that of the cable feed system hood, i.e. 10 mm.
- ② Cables laid in the cable duct
- ③ Roof gland HDZ 100, not included in the scope of delivery

5.1.6 Installing the Turntable



The sequence of pictures shown below illustrates all the necessary installation steps that are required to install the turntable and the pre-assembled parabolic reflector on the roof of the vehicle. However, follow the other detailed instructions in this installation and operating manual!



1. Determine the installation location. Note the following:
 - Swing path of the unit = Ø 162 cm.
 - Drill a hole with Ø 38 mm for the cable gland.
 - Deburr any sharp edges of the hole.

See also 5.1.3, p. 13ff and 5.1.4 – 5.1.5, p. 16ff



2. Apply DEKAsyl MS adhesive sealant to the spigot of the roof duct. Insert the spigot into the hole and secure it from below with the knurled nut.



3. Unscrew the screws (x 6, 10 AF) from the mounting plate and remove the mounting plate.



4. Place the turntable on prepared wooden supports to protect the roof of the vehicle.



5. Align the mounting plate with the arrow in the direction of travel. The arrow is marked with an ⓐ at step 8 in the illustration.
6. Mark out the six holes to secure the mounting plate.



- 7.



WARNING

Risk of skin injuries!

- ▶ Avoid any skin contact with the adhesive sealant.
- ▶ For safety information on the adhesive sealant, see Chapter 11, p. 34.

Apply DEKAsyl MS adhesive sealant in a wavy line between the two grooves and spread it with a spatula or similar.

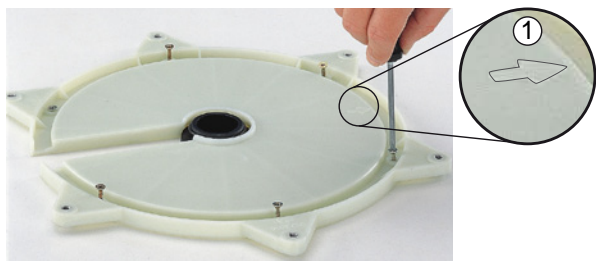

8. Place the mounting plate on the roof gland and secure it with the appropriate screws (choose screws according to thickness/structure of roof).



9. Screw the turntable onto the mounting plate using the torque wrench.



NOTICE

Risk of material damage due to an inadmissible tightening torque!

If the torque is too high, it can destroy the thread in the mounting plate. If the torque is too low, the screws can unscrew due to vibrations.

- Comply with the tightening torque of 6 Nm.

10. Make the electrical connections.
11. Connect the CAP converter.
12. Connect the turntable to the battery.

5.2 Installing and Connecting the CAP Converter

5.2.1 Selecting an Installation Location

Tip

When choosing the installation location, bear in mind that the rear of the CAP converter should always be accessible. The CAP converter is equipped with a power saving circuit, which means that you do not have to place it where it is visible. Therefore, you can fit the CAP converter out of sight in any location, e.g. on cupboard walls, side walls or the base of storage compartments.

With the help of the four screw sockets (see *Preparing the CAP Converter for Installation*, p. 22) it is possible to install the CAP converter on a solid even base or to screw it in any position.

When selecting an installation location, pay attention to the following:

- The wall thickness at the installation location must be at least 15 mm, as otherwise the screws will break through on the other side or damage the surface.
- Ensure that the cupboard or storage compartment in which the unit is housed is adequately ventilated, to prevent a build up of heat. Carpet-covered walls are unsuitable for installation.
- Take care when tightening the screws not to damage any cables or similar behind or in the wall.
- The CAP converter is designed for installation in exclusively dry, interior locations.
- Take into account the cable lengths.
- The connecting cables must be provided with strain reliefs.

Ventilation

The heat generated within the CAP converter can be dissipated from all sides of the casing. When selecting the installation location, make sure that these sides are not obstructed or covered. If the unit is operated continuously with insufficient ventilation, this can negatively affect the length of its working life!

Maintain a clearance of at least 20 cm above and below the unit, 2 cm to either side and 5 cm behind and in front of it, to allow unobstructed dissipation of the heat generated.

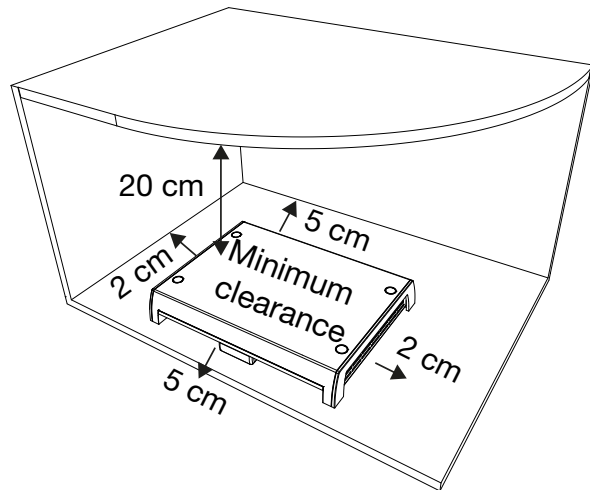

NOTICE

Risk of material damage caused by insufficient ventilation!

The unit monitors its own temperature in operation. Continuous operation at temperatures higher than the recommended operating temperature can cause premature failure of the unit as a result of insufficient ventilation. This does not constitute grounds for a claim under warranty/guarantee!

- ▶ Operate the CAP converter only at the recommended operating temperature.

Connections and Fusing of the Unit

All the connecting cables for connection to the CAP converter are attached at the rear of the unit, see also Section 5.2.9, p. 27.

On the left-hand side of the CAP converter viewed from the front, there is a fuse inserted from the outside. This fuse must be accessible even after the unit has been installed, so that it can easily be exchanged if required. For more information about the fuse, see stickers on the CAP converter and the fuse.

5.2.2 Preparing the CAP Converter for Installation

Removing the Blanking Plugs

When the unit is delivered, the screw sockets are covered with blanking plugs. Push these out, using the screws supplied working upwards from below in the direction of arrow, see diagram on the right.

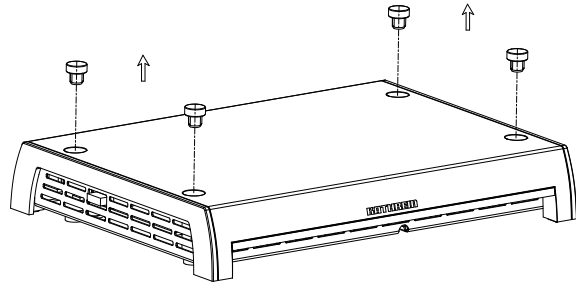

Marking out the Screw/Drill Points at the Installation Location:

Use the diagram below for the intervals between screw/drill points:

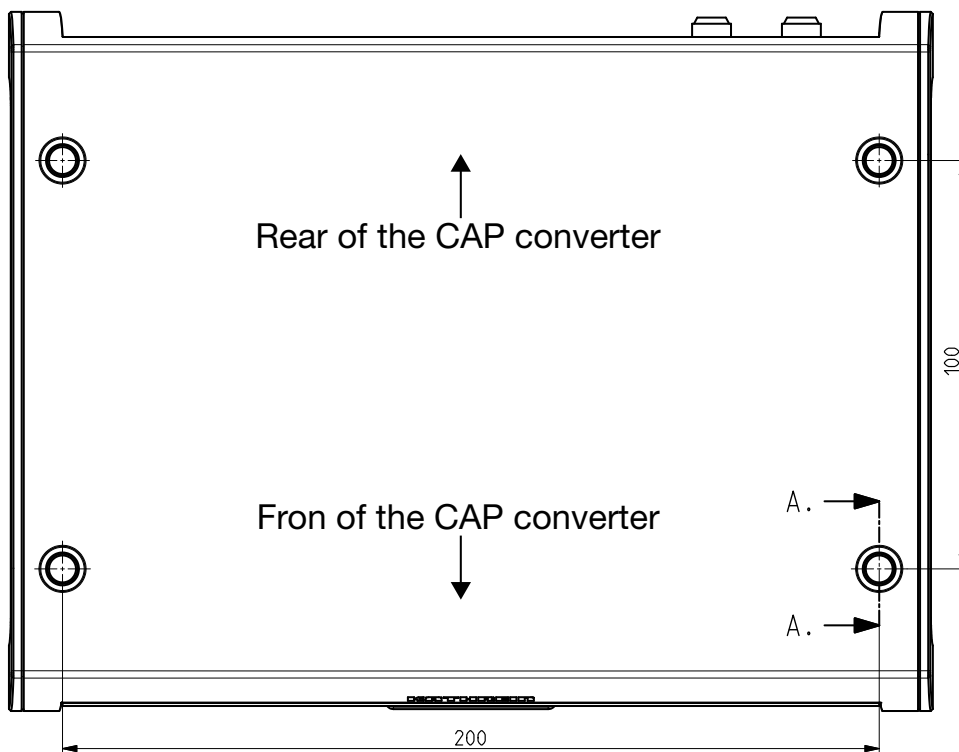

5.2.3 Important Instructions for Installation



DANGER

Danger to life from electric shock!

The wood screws could make contact with electrically live parts and lead to danger to life from electric shock.

- ▶ Do not use the wood screws included in the CAP converter scope of delivery to mount it onto another electrical device, e.g. a TV set.



NOTICE

Risk of material damage when using countersunk head screws!

- ▶ Under no circumstances use countersunk head screws for installation (see figure on the right).
- ▶ Use the wood screws supplied with the CAP converter.





NOTICE

Risk of malfunction or material damage due to overheating!

If the CAP converter is attached to another electrical device, e.g. a TV set, the temperature rise of each unit in operation can affect the other, thus causing overheating.

- ▶ Before installing the CAP converter on another electrical device, check with the manufacturer of the device or in the documentation supplied with it whether this is permissible, and if so, what fittings (screws, etc.) are necessary or can be used.

Using other Screws

If because of the installation location or factors associated with it, the screws supplied cannot be used, refer to the figure on the right when selecting the screws to be used. The figure shows you the cross-section area of the screw sockets on the CAP converter. From this, it is possible to see the characteristics of the screws which can be inserted into the receiver support, e.g. diameter, screw head profiles etc.

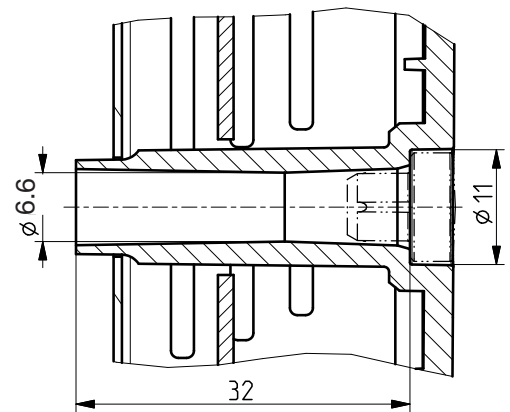

5.2.4 Installing the CAP Converter on a TV Set



DANGER

Danger to life from electric shock!

If the screws penetrate too deeply into the TV set, they may damage it beyond repair and cause the risk of a fatal electric shock.

- ▶ Before starting any installation work, disconnect all the units concerned from the mains.
- ▶ Before installing the CAP converter on another electrical device, check with the manufacturer of the device or by reference to the documentation supplied with it whether this is permissible, and if so, what fittings (screws, etc.) are necessary or can be used.



CAUTION

Risk of material damage and injuries from overheating and fire!

- ▶ Under no circumstances install the CAP converter between a TV set and a wall support.
- ▶ Installation of the CAP converter on the rear panel of a TV set is permissible only if the TV set is resting on a stand that is attached in some other way.

For installation on the rear panel of a TV set, securing with two screws is sufficient. Before installing the CAP converter, pay attention to the following:

- The TV set must have one of the following hole patterns for wall mounting on its rear panel: 100 x 100; 100 x 200; 200 x 200 or 200 x 400. If this is not the case, a VESA adaptor plate can be obtained from a specialist dealer.
- Before installing the receiver it is essential you read the section *Wall mounting* (or the equivalent) in the user instructions for your TV set. This will tell you the screw diameters (M4, M6 or M8) and, most importantly, the permissible screw penetration depth.

5.2.5 Installing the CAP Converter



NOTICE

Risk of material damage from applying too much force when tightening the screws!

If you apply too much force when tightening the screws, you can damage the screw sockets and the CAP converter casing or any cables already attached to it.

► Tighten the screws carefully.

Example for mounting on wood:

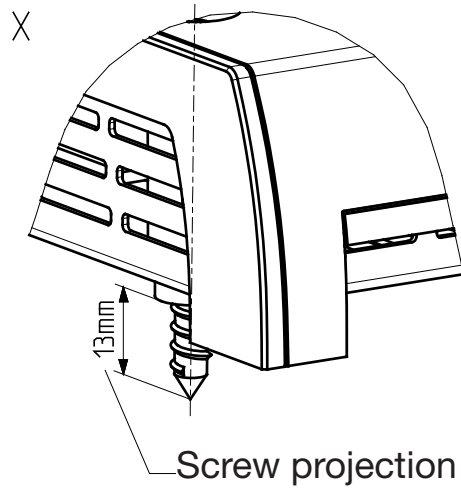
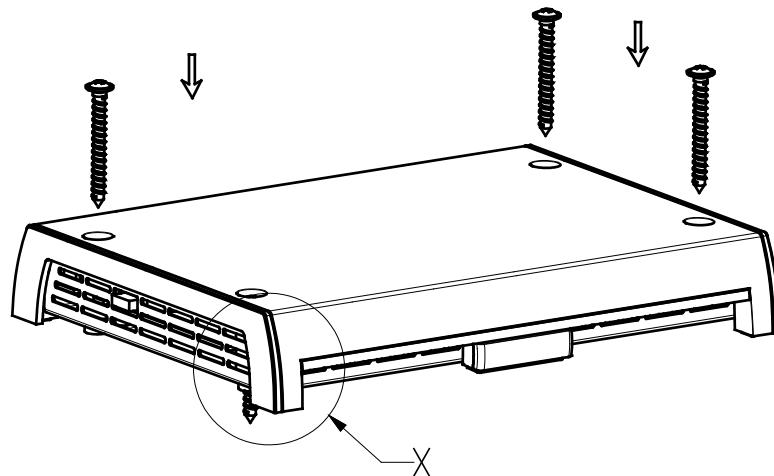

5.2.6 Laying the Cables and Connecting the Turntable



NOTICE

Risk of damage to cables from sharp edges and chafing points!

- ▶ Do not lay cables across sharp edges.
 - ▶ Protect cables against possible chafing points.
-

1. Connect the master coaxial cable (marked red) to the CAP converter and the slave coaxial cable to a second TV with a built-in receiver or a second receiver (if available).

Tip

If you do not use a second receiver, we recommend attaching the slave coaxial cable nonetheless, in case you might need it at a later time.

2. Lay the turntable power supply cable (3-pin plug) to the battery. If necessary, use the power supply extension cable.
3. Connect the master coaxial cable to the *IF INPUT* socket at the rear of the CAP converter. If necessary, use the coaxial extension cable.

5.2.7 Connecting the CAP Converter



WARNING

Risk of severe injuries due to cable fire!

If you remove or bypass the fuse in the cable, it can cause cable fire.

- ▶ Do not remove or bypass the fuse in the cable.
-



NOTICE

Risk of material damage due to incorrect supply voltage!

At the connecting point for the power cable, the voltage must not fall below 10.9 V even with a load of 12 A. Otherwise, optimum functioning can no longer be guaranteed.

- ▶ Connect the CAP converter to no other power supply than 12 V.
 - ▶ Connect the earth pole of the CAP converter to the negative pole of the motor home or caravan battery.
-



NOTICE

Risk of material damage due to the absence of a blade fuse in the cable!

- ▶ Protect the positive wire (red) of the power supply cable by using a 15 A blade fuse.
 - ▶ The fuse must be installed by a specialist.
 - ▶ If the fuse is blown, replace it by a fuse of the same rating (15 A).
 - ▶ Eliminate the cause of the fault.
-



NOTICE

Risk of malfunction and material damage due to reversed polarity!

When connecting the power cables, reversed polarity can lead to thermal overload and damage to components when the equipment is powered up. If the earth of the ignition signal and the earth of the vehicle battery for the turntable do not have the same potential, the automatic antenna lowering does not function!

- ▶ When connecting the power cables (CAP converter and turntable) to the vehicle electrical system, make sure that the poles are not reversed.
 - ▶ Make sure that the earth of the ignition signal and the earth of the vehicle battery for the turntable have the same potential.
-

1. Before commencing the work, isolate the on-board power supply. To do so, move the master switch to the off position or disconnect the positive pole of the on-board power supply battery.
2. Connect the 12 V power supply cable to the **12 V =/2,5 A** socket on the CAP converter.
3. Connect the other end of the 12 V power supply cable to a 12 V socket in your motor home or caravan.

Tip Only for motor homes

The third, green connecting cable, marked **IGNITION** allows you to connect to a circuit in the vehicle that is activated when the ignition key is turned and then carries a continuous 12 V supply. This type of connection ensures that when the engine is started, the antenna is automatically lowered into the park position (the CAP converter does not need to be turned on).

Note that the antenna can be lowered only if the power supply is present in addition to the ignition signal!

4. Check the connections before you reconnect to the on-board power supply.

For more information on commissioning and additional operator functions, see the operating instructions in this manual.

5.2.8 Functional Instructions for Connection to the On-board Power Supply

Under certain circumstances, problems can arise when the units are connected to different connecting sockets or circuits/earth potentials. If no others are available, it is recommended that you connect the connecting sockets for the CAP converter and TV set to the same cable, as shown in Fig. G. Check the power rating of the circuit used with respect to the intended application.

5.2.9 Connection Example for 12 V Battery Connection

Fig. G

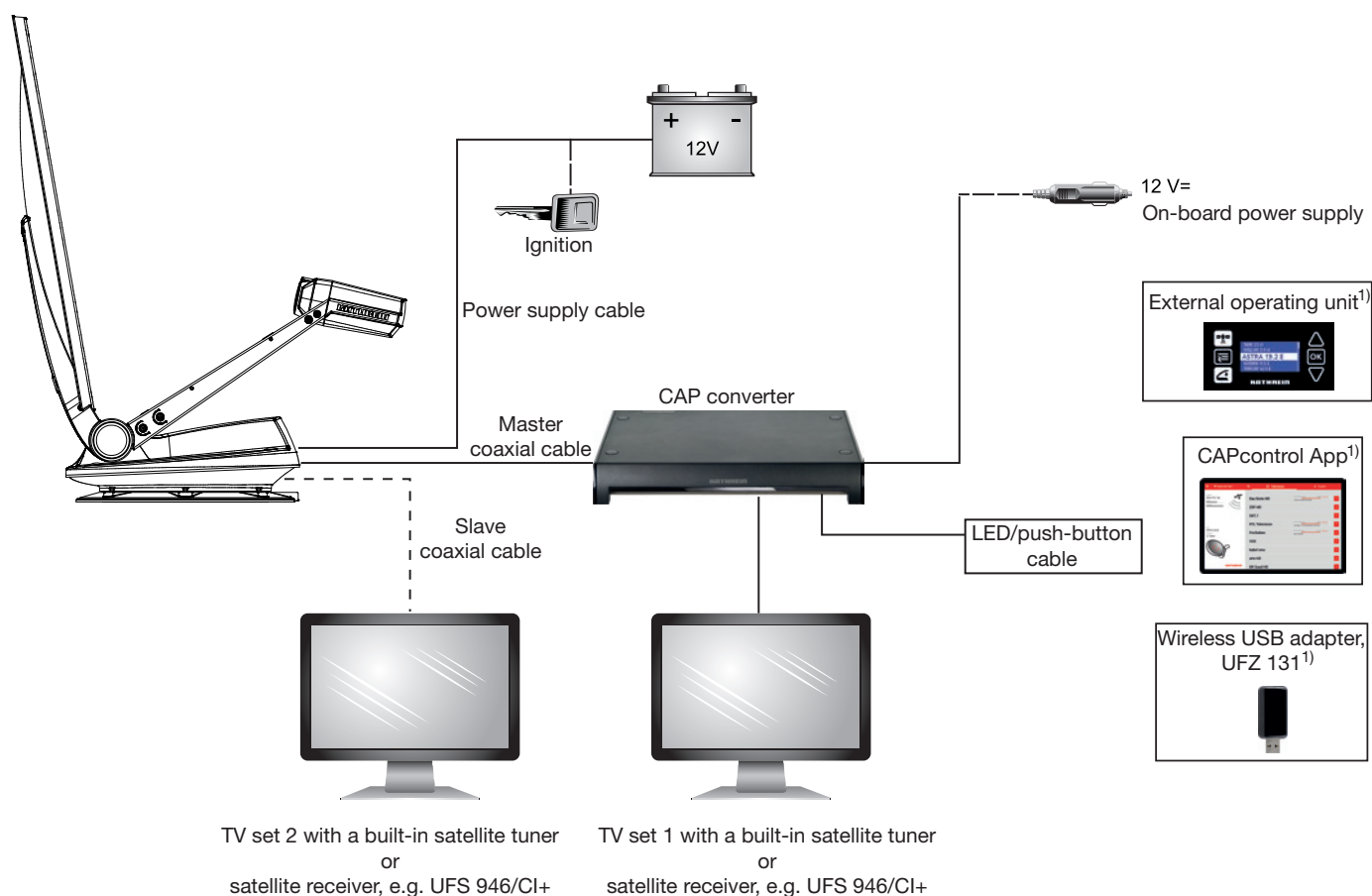

¹⁾ Available as accessories. For more information, go to www.kathrein.com.

6 Reception Range/Footprint

The footprint is the reception area on the earth that a satellite covers with its transmission beam (spot), within which satellite reception is possible. The transmission power is at its greatest in the centre of this spot – it becomes progressively weaker moving outwards.

The satellites broadcast various channel packages in different footprints. Normally all program packages can be received within the spots. While reception is possible in principle at the edge zones, the quality depends on various factors, such as the diameter of the satellite antenna and the weather conditions.

Fig. G shows the spots of the most commonly used satellites for the antenna of the CAP 950.

The inner line of the footprint here shows the area covered by the digital signals from the ASTRA 19.2° East and the outer line for the EUTELSAT/HOTBIRD 13° East.

Fig. H: Spot ASTRA 19.2° East (inner line) and EUTELSAT/HOTBIRD 13° East (outer line)

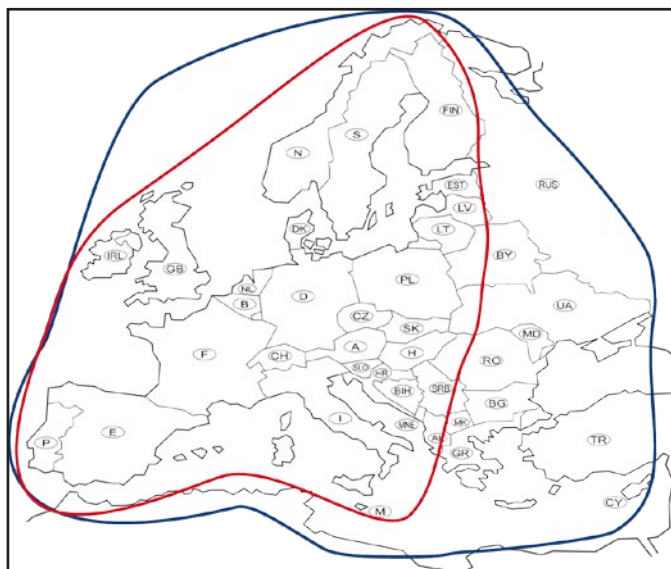

7 Dismantling for Servicing

If repairs to the system or individual components are necessary, contact your specialist dealer or our service centre (see the address below).



CAUTION

Risk of injuries when opening the turntable!

- ▶ Do not open the turntable yourself.



NOTICE

Risk of material damage when cutting the cables!

- ▶ Do not cut the cables.
- ▶ At the cable junction provided, disconnect the cables projecting from the turntable from the cables laid within the interior of the vehicle (unplug the plug).

7.1 Dismantling the Turntable

1. Move the turntable to the park position.

Tip The cables laid within the vehicle can remain there.

2. Unscrew the six M6 screws which secure the turntable to the mounting plate.
3. Place two wooden supports on the vehicle roof for protection.
4. Place the turntable on the prepared wooden supports.
5. Use the original packaging to ship the turntable.
6. Seal the opening in the vehicle roof appropriately to protect against the ingress of moisture.
7. If an HDZ 100 roof duct has been fitted and the equipment is removed, seal the cable glands that are no longer used with the integral plugs.
 - ⇒ The casing is watertight again.

7.2 Address of the Service Centre

Main factory repair centre

CSS Caravan-Sat-Service GmbH

Bahnhofstr. 110
83224 Grassau, Germany

Phone: 08641 6998427

Fax: 08641 6998429

E-mail: service@css-grassau.de

Regional repair centre

KATHREIN Sachsen GmbH

Lindenstraße 3
09241 Mühlau, Germany

Phone: 03722 6073-31

Fax: 03722 6073-18

E-mail: service@kathrein-sachsen.de

8 Polarisation Setting

The polarisations setting is required to compensate for the so-called skew. The skew is the discrepancy between the vertical polarisation of the received signal from the geographical verticals. For optimal reception, the LNB must be installed before the satellite disk, inclined by the skew angle.

The CAP 950 calculates the skew angle on the basis of the GPS data and inclines the LNB fully automatically. The prerequisite for this is that valid GPS data are available.

9 Manually Lowering the Antenna to Park Position



NOTICE

Risk of material damage due to a defect in the electronic controls!

If there is a defect in the electronic controls, the antenna cannot lower to the park position automatically. After some disassembly work, the satellite dish can be put to the park position manually. Before manually lowering the antenna, note the following:

- ▶ Drive to the nearest workshop at a moderate speed with the antenna extended, taking into account the increase of +72 cm in the vehicle height. **Driving to the nearest workshop is preferable to the manual lowering!**
- ▶ Do not attempt to lower the antenna manually to the park position yourself if you are unfamiliar with the necessary repair work. Contact a technician or try to find a suitable person on the campsite.
- ▶ It is necessary to recalibrate the antenna in an authorised workshop after it has been manually lowered to the park position.

9.1 Safety Instructions



WARNING

- ▶ Follow general safety instructions; see *Safety Instructions and General Guidelines*, p. 7.



WARNING

Risk of severe injuries when dismantling on the vehicle roof!

- ▶ Do not hold onto the antenna, as the rocker can suddenly come free.



WARNING

Risk of severe injuries from moving or falling parts or crushing!

When removing the screws from the turntable, the rocker may suddenly come loose. It is then no longer connected to the turntable!



- ▶ During dismantling, always disconnect all the units from the power supply.
- ▶ Secure and support the antenna to prevent it from tipping over.

9.2 Manual Lowering



1. Using a narrow flat-bladed screwdriver, lever the plastic cap in the centre of the axis (see the arrow in the figure on the left).
⇒ You can see the following hexagon socket head cap screws:
1x M10 (WAF 8 mm) on each side, 2x M6 (WAF 5 mm) on one side.
2. Remove the four hexagon socket head caps.
⇒ You can see another thread on each side.
- 3.



NOTICE

Risk of material damage!

- ▶ Screw in the M12 screw only as far as to free the rocker from the engagement on the tapered shaft.

Screw an M12 x 40 screw (minimum length: 40 mm) into this thread on each side.

- ⇒ The rocker is pushed off the taper seating on the tapered shaft and the engagement is released.
4. Tilt the antenna to the park position.
 5. Remove the M12 screw.
⇒ You can put the rocker back on the tapered shaft.
 6. Replace the four hexagon socket head cap screws and tighten them firmly (1x M10 on each side, 2x M6 on one side).
 7. Replace the plastic cap.



NOTICE

Rocker displacement!!

Due to the loosening the rocker from the tapered shaft, the rocker zero point position is lost.

- ▶ It is necessary that an authorised dealer recalibrates the rocker.

8. Consult an authorised dealer.

10 Technical Data

10.1 Technical Data

Type	Unit	CAP 950
Order no.		20310032
LNB		2 switchable outputs: V/H (14/18 V) Low/High (0/22 kHz)
Supply voltage LNB	V	Vertical: 11,5 – 14 Horizontal: 16 – 19
Input frequency	GHz	10.70 – 12.75
Output frequency	MHz	950 – 1950/1100 – 2150
Oscillator frequency (L. O.)	GHz	9.75/10.60
System quality (G/T) at 11.3/12.5 GHz	dB/K	16.9/17.9
Power supply (vehicle battery)	V	11.5 – 13.8
Power consumption from the 12 electrical system Inrush current Satellite search TV reception Standby	A	Typ. 10, max. 12 Typ. 3 Typ. 1.2 Typ. 0.024
Power consumption from the CAP converter	mA	Typ. 200
Setting range Elevation Azimuth Skew	°	0 – 112 370 ±45
Weight of the turntable with parabolic reflector	kg	18.9
Packing unit/weight	units/ kg	1/32.5
Ignition signal		12 – 24 V
Search time for the first satellite		typ. 10 – 120 s
Search time for further satellites		typ. 2 – 30 s
Startup time LSM ¹⁾		5 – 30 s

¹⁾ LSM = Last Satellite Position

10.2 Dimensions (in mm)

← Fahrtrichtung / driving direction / sens de la marche

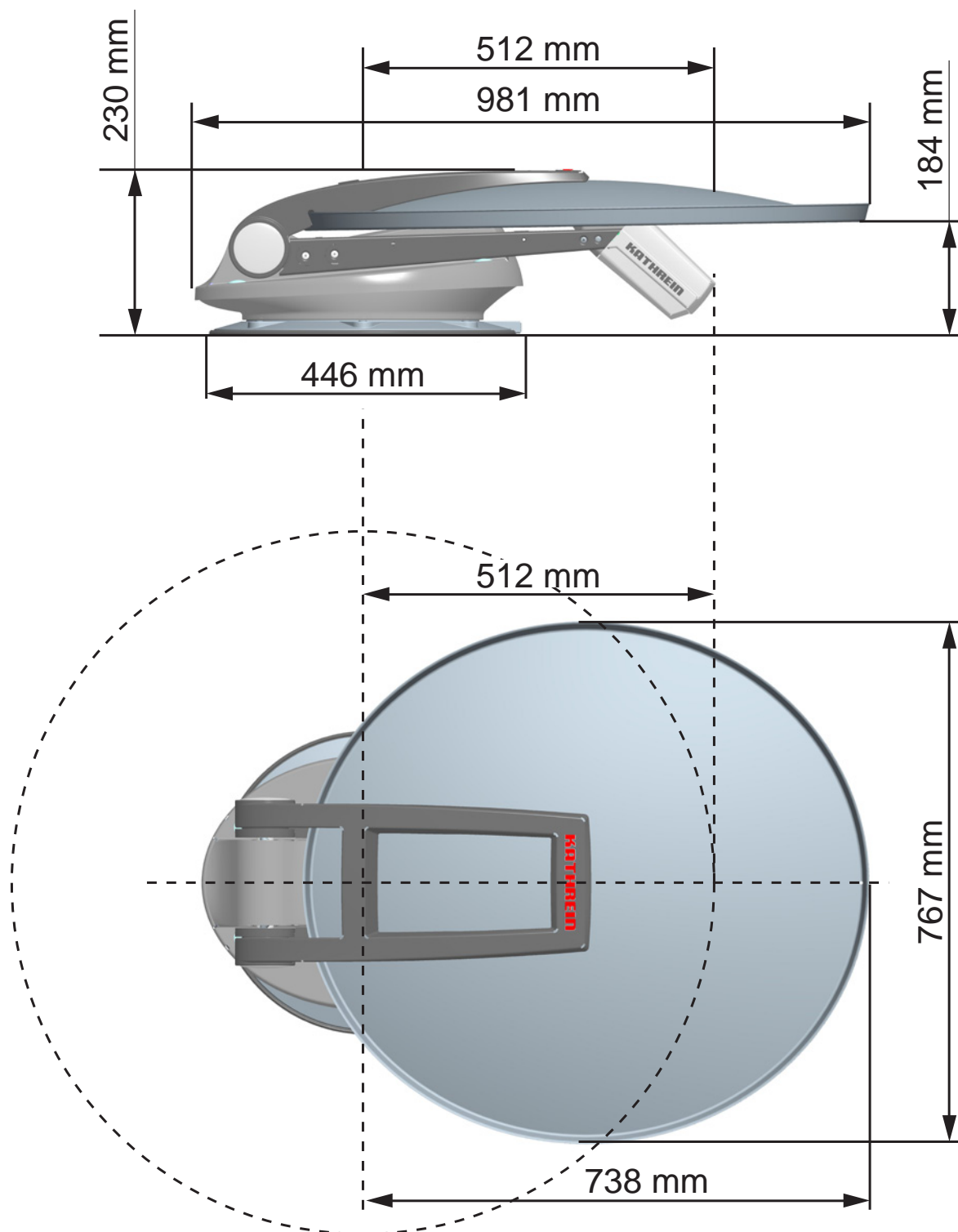

11 DEKAsyl MS Safety Data Sheet

Page 1/7



Safety data sheet
according to 1907/2006/EC, Article 31

Printing date 29.05.2015

Version number 13

Revision: 29.05.2015

SECTION 1: Identification of the substance/mixture and of the company/undertaking

- **1.1 Product identifier**
- **Trade name: Dekasyl MS-5**
- **1.2 Relevant identified uses of the substance or mixture and uses advised against**
No further relevant information available.
- **Application of the substance / the mixture**
Sealant
Glue/ Sising agent
- **1.3 Details of the supplier of the safety data sheet**
- **Manufacturer/Supplier:**
Dekalin, brand of Diffutherm B.V.
Smaragdweg 50
NL-5527 LB Hapert
Tel: +31 497 551 080
Fax: +31 497 551 088
E-mail: info@dekalin.nl
- **Further information obtainable from:** Product safety Department
- **1.4 Emergency telephone number:**
National Poisons Information Center (NVIC)
TEL: +31 (0)30-2748888
Only for the purpose of informing medical personnel in cases of acute intoxications

SECTION 2: Hazards identification

- **2.1 Classification of the substance or mixture**
- **Classification according to Regulation (EC) No 1272/2008**
The product is not classified according to the CLP regulation.
- **Classification according to Directive 67/548/EEC or Directive 1999/45/EC** Not applicable.
- **Information concerning particular hazards for human and environment:**
The product does not have to be labelled due to the calculation procedure of the "General Classification guideline for preparations of the EU" in the latest valid version.
- **Classification system:**
The classification is according to the latest editions of the EU-lists, and extended by company and literature data.
- **2.2 Label elements**
- **Labelling according to Regulation (EC) No 1272/2008** Void
- **Hazard pictograms** Void
- **Signal word** Void
- **Hazard statements** Void
- **Additional information:**
Safety data sheet available on request.
- **2.3 Other hazards**
- **Results of PBT and vPvB assessment**
- **PBT:** Not applicable.
- **vPvB:** Not applicable.

SECTION 3: Composition/information on ingredients

- **3.2 Chemical characterisation: Mixtures**
- **Description:** Mixture of substances listed below with additions.
- **Dangerous components:**

(Contd. on page 2)

GB

Trade name: Dekasyl MS-5

		(Contd. of page 1)
EC number: 907-495-0 Reg.nr.: 01-2119545465-35	Reaction mass of Octadecanamide, 12-hydroxy-N-[2-[(1-oxodecyl)amino]ethyl]- and N,N'-ethane-1,2-diylbis(12-hydroxyoctadecan-1-amide) and Decanamide, N,N'-1,2-ethanediylbis-R52 ----- Aquatic Chronic 3, H412	1-<5%
CAS: 2768-02-7 EINECS: 220-449-8	Trimethoxyvinylsilan ☒ Xn R20 R10 ----- ☒ Flam. Liq. 3, H226; ☒ Acute Tox. 4, H332	1-<5%
CAS: 25973-55-1 EINECS: 247-384-8	phenol, 2-(2h-benzotriazol-2-yl)-4,6-bis(1,1-dimethylpropyl) ☒ Xn R48/22 R53 ----- ☒ STOT RE 2, H373; Aquatic Chronic 3, H412	<1%

· SVHC

25973-55-1 phenol, 2-(2h-benzotriazol-2-yl)-4,6-bis(1,1-dimethylpropyl)

· **Additional information:** For the wording of the listed risk phrases refer to section 16.

SECTION 4: First aid measures

- **4.1 Description of first aid measures**
- **General information:** No special measures required.
- **After inhalation:** Supply fresh air; consult doctor in case of complaints.
- **After skin contact:**
Immediately wash with water and soap and rinse thoroughly.
If skin irritation continues, consult a doctor.
- **After eye contact:**
Rinse opened eye for several minutes under running water. If symptoms persist, consult a doctor.
- **After swallowing:** Wash out mouth with water. Contact a physician.
- **4.2 Most important symptoms and effects, both acute and delayed** No further relevant information available.
- **4.3 Indication of any immediate medical attention and special treatment needed**
No further relevant information available.

SECTION 5: Firefighting measures

- **5.1 Extinguishing media**
- **Suitable extinguishing agents:**
CO₂, powder or water spray. Fight larger fires with water spray or alcohol resistant foam.
- **5.2 Special hazards arising from the substance or mixture**
In case of fire, the following can be released:
Carbon monoxide (CO)
- **5.3 Advice for firefighters**
- **Protective equipment:** Mount respiratory protective device.
- **Additional information** Cool endangered receptacles with water spray.

SECTION 6: Accidental release measures

- **6.1 Personal precautions, protective equipment and emergency procedures** Not required.
- **6.2 Environmental precautions:** Do not allow to enter sewers/ surface or ground water.
- **6.3 Methods and material for containment and cleaning up:**
Absorb with liquid-binding material (sand, diatomite, acid binders, universal binders, sawdust).
- **6.4 Reference to other sections**
No dangerous substances are released.
See Section 7 for information on safe handling.
See Section 8 for information on personal protection equipment.

(Contd. on page 3)



Safety data sheet
according to 1907/2006/EC, Article 31

Printing date 29.05.2015

Version number 13

Revision: 29.05.2015

Trade name: Dekasyl MS-5

See Section 13 for disposal information.

(Contd. of page 2)

SECTION 7: Handling and storage

- **7.1 Precautions for safe handling**
No special measures required.
Use only in well ventilated areas.
- **Information about fire - and explosion protection:** No special measures required.
- **7.2 Conditions for safe storage, including any incompatibilities**
- **Storage:**
- **Requirements to be met by storerooms and receptacles:** No special requirements.
- **Information about storage in one common storage facility:** Not required.
- **Further information about storage conditions:** None.
- **7.3 Specific end use(s)** No further relevant information available.

SECTION 8: Exposure controls/personal protection

- **Additional information about design of technical facilities:** No further data; see item 7.
- **8.1 Control parameters**
- **Ingredients with limit values that require monitoring at the workplace:**
The product does not contain any relevant quantities of materials with critical values that have to be monitored at the workplace.
- **CAS No. Designation of material % Type Value Unit** Not required.
- **Additional information:** The lists valid during the making were used as basis.
- **8.2 Exposure controls**
- **Personal protective equipment:**
- **General protective and hygienic measures:**
The usual precautionary measures are to be adhered to when handling chemicals.
- **Respiratory protection:** Not required.
- **Protection of hands:** Protective gloves and protective skin cream
- **Material of gloves**
PVC or PE gloves
The selection of the suitable gloves does not only depend on the material, but also on further marks of quality and varies from manufacturer to manufacturer. As the product is a preparation of several substances, the resistance of the glove material can not be calculated in advance and has therefore to be checked prior to the application.
Recommended thickness of the material: $\geq 0,12$ mm
- **Penetration time of glove material**
> 480 min.
The exact break trough time has to be found out by the manufacturer of the protective gloves and has to be observed.
- **Eye protection:** Goggles recommended during refilling

SECTION 9: Physical and chemical properties

- **9.1 Information on basic physical and chemical properties**
- **General Information**
- **Appearance:**
- **Form:** Pasty
- **Colour:** According to product specification
- **Odour:** Characteristic
- **Odour threshold:** Not determined.

(Contd. on page 4)

GB

Safety data sheet
according to 1907/2006/EC, Article 31

Printing date 29.05.2015

Version number 13

Revision: 29.05.2015

Trade name: Dekasyl MS-5

(Contd. of page 3)

· pH-value:	<i>Not determined.</i>
· Change in condition	
<i>Melting point/Melting range:</i>	<i>Undetermined.</i>
<i>Boiling point/Boiling range:</i>	<i>Undetermined.</i>
· Flash point:	<i>Not applicable.</i>
· Flammability (solid, gaseous):	<i>Not applicable.</i>
· Ignition temperature:	
<i>Decomposition temperature:</i>	<i>Not determined.</i>
· Self-igniting:	<i>Product is not selfigniting.</i>
· Danger of explosion:	<i>Product does not present an explosion hazard.</i>
· Explosion limits:	
<i>Lower:</i>	<i>Not determined.</i>
<i>Upper:</i>	<i>Not determined.</i>
· Vapour pressure:	<i>Not determined.</i>
· Density At 20 °C:	<i>1.5 g/cm³ (DIN 51757)</i>
· Relative density	<i>Not determined.</i>
· Vapour density	<i>Not determined.</i>
· Evaporation rate	<i>Not determined.</i>
· Solubility in / Miscibility with water:	<i>Not miscible or difficult to mix.</i>
· Partition coefficient (n-octanol/water):	<i>Not determined.</i>
· Viscosity:	
<i>Dynamic:</i>	<i>Not determined.</i>
<i>Kinematic:</i>	<i>Not determined.</i>
· Solvent content:	
<i>Organic solvents:</i>	<i>0.0 %</i>
<i>Solids content:</i>	<i>97.0 % (DIN 53216)</i>
· 9.2 Other information	<i>No further relevant information available.</i>
· VOC (EU):	<i>0.00 %</i>
· VOCV:	<i>0.00 %</i>

SECTION 10: Stability and reactivity

- **10.1 Reactivity**
- **10.2 Chemical stability**
- **Thermal decomposition / conditions to be avoided:** *No decomposition if used according to specifications.*
- **10.3 Possibility of hazardous reactions** *No dangerous reactions known.*
- **10.4 Conditions to avoid** *No further relevant information available.*
- **10.5 Incompatible materials:** *No further relevant information available.*

SECTION 11: Toxicological information

- **11.1 Information on toxicological effects**
- **Acute toxicity:**

 · **LD/LC50 values relevant for classification:**
ATE (Acute Toxicity Estimates)

Inhalative	LC50/4 h	368 mg/l
------------	----------	----------

(Contd. on page 5)



Safety data sheet
according to 1907/2006/EC, Article 31

Printing date 29.05.2015

Version number 13

Revision: 29.05.2015

Trade name: Dekasyl MS-5

(Contd. of page 4)

- **Primary irritant effect:**
- **on the skin:** No irritant effect.
- **on the eye:** No irritating effect.
- **Sensitisation:** No sensitising effects known.
- **Additional toxicological information:**
The product is not subject to classification according to the calculation method of the General EU Classification Guidelines for Preparations as issued in the latest version.
When used and handled according to specifications, the product does not have any harmful effects to our experience and the information provided to us.

SECTION 12: Ecological information

- **12.1 Toxicity**
- **Aquatic toxicity:** No further relevant information available.
- **12.2 Persistence and degradability** No further relevant information available.
- **12.3 Bioaccumulative potential** No further relevant information available.
- **12.4 Mobility in soil** No further relevant information available.
- **Additional ecological information:**
- **General notes:**
Water hazard class 1 (German Regulation) (Self-assessment): slightly hazardous for water
Do not allow undiluted product or large quantities of it to reach ground water, water course or sewage system.
- **12.5 Results of PBT and vPvB assessment**
- **PBT:** Not applicable.
- **vPvB:** Not applicable.
- **12.6 Other adverse effects** No further relevant information available.

SECTION 13: Disposal considerations

- **13.1 Waste treatment methods**
- **Recommendation** Smaller quantities can be disposed of with household waste.

- **European waste catalogue**

08 00 00	WASTES FROM THE MANUFACTURE, FORMULATION, SUPPLY AND USE (MFSU) OF COATINGS (PAINTS, VARNISHES AND VITREOUS ENAMELS), ADHESIVES, SEALANTS AND PRINTING INKS
08 04 00	wastes from MFSU of adhesives and sealants (including waterproofing products)
08 04 10	waste adhesives and sealants other than those mentioned in 08 04 09

- **Uncleaned packaging:**
- **Recommendation:** Disposal must be made according to official regulations.

SECTION 14: Transport information

- | | |
|--|------|
| · 14.1 UN-Number | |
| · ADR, ADN, IMDG, IATA | Void |
| · 14.2 UN proper shipping name | |
| · ADR, ADN, IMDG, IATA | Void |
| · 14.3 Transport hazard class(es) | |
| · ADR, ADN, IMDG, IATA | |
| · Class | Void |
| · 14.4 Packing group | |
| · ADR, IMDG, IATA | Void |

(Contd. on page 6)

GB

Safety data sheet
according to 1907/2006/EC, Article 31

Printing date 29.05.2015

Version number 13

Revision: 29.05.2015

Trade name: Dekasyl MS-5

(Contd. of page 5)

· 14.5 Environmental hazards:	
· Marine pollutant:	No
· 14.6 Special precautions for user	Not applicable.
· 14.7 Transport in bulk according to Annex II of MARPOL73/78 and the IBC Code	Not applicable.
· Transport/Additional information:	Not dangerous according to the above specifications. Transport classification ADR/IMDG is based on packaging >30ltr(IMDG), <450ltr(ADR). For other packaging units different classification can apply.
· UN "Model Regulation":	-

SECTION 15: Regulatory information

- **15.1 Safety, health and environmental regulations/legislation specific for the substance or mixture**
 - **Labelling according to Regulation (EC) No 1272/2008** Void
 - **Hazard pictograms** Void
 - **Signal word** Void
 - **Hazard statements** Void
 - **National regulations:**
 - **Waterhazard class:** Water hazard class 1 (Self-assessment): slightly hazardous for water.
 - **Other regulations, limitations and prohibitive regulations**
- | |
|--|
| · Substances of very high concern (SVHC) according to REACH, Article 57 |
| 25973-55-1 phenol, 2-(2h-benzotriazol-2-yl)-4,6-bis(1,1-dimethylpropyl) |
- **15.2 Chemical safety assessment:** A Chemical Safety Assessment has not been carried out.

SECTION 16: Other information

This information is based on our present knowledge. However, this shall not constitute a guarantee for any specific product features and shall not establish a legally valid contractual relationship.

- **Relevant phrases**
 H226 Flammable liquid and vapour.
 H332 Harmful if inhaled.
 H373 May cause damage to organs through prolonged or repeated exposure.
 H412 Harmful to aquatic life with long lasting effects.
- **R10** Flammable.
- **R20** Harmful by inhalation.
- **R48/22** Harmful: danger of serious damage to health by prolonged exposure if swallowed.
- **R52** Harmful to aquatic organisms.
- **R53** May cause long-term adverse effects in the aquatic environment.
- **Department issuing MSDS:** Product safety department.
- **Contact:** info@dekalin.nl
- **Abbreviations and acronyms:**
 RID: Règlement international concernant le transport des marchandises dangereuses par chemin de fer (Regulations Concerning the International Transport of Dangerous Goods by Rail)
 ICAO: International Civil Aviation Organisation
 ADR: Accord européen sur le transport des marchandises dangereuses par Route (European Agreement concerning the International Carriage of Dangerous Goods by Road)
 IMDG: International Maritime Code for Dangerous Goods
 IATA: International Air Transport Association
 GHS: Globally Harmonised System of Classification and Labelling of Chemicals
 EINECS: European Inventory of Existing Commercial Chemical Substances

(Contd. on page 7)



Safety data sheet
according to 1907/2006/EC, Article 31

Page 7/7

Printing date 29.05.2015

Version number 13

Revision: 29.05.2015

Trade name: Dekasyl MS-5

(Contd. of page 6)

*ELINCS: European List of Notified Chemical Substances**CAS: Chemical Abstracts Service (division of the American Chemical Society)**LC50: Lethal concentration, 50 percent**LD50: Lethal dose, 50 percent**Flam. Liq. 3: Flammable liquids, Hazard Category 3**Acute Tox. 4: Acute toxicity, Hazard Category 4**STOT RE 2: Specific target organ toxicity - Repeated exposure, Hazard Category 2**Aquatic Chronic 3: Hazardous to the aquatic environment - Chronic Hazard, Category 3*

GB

12 DEKAsyl MS Technical Data Sheet



HIGH QUALITY PRODUCTS
FOR MOTORHOME, CARAVAN AND TRAILER TENT

TECHNICAL DATA SHEET

DEKASYL MS-5 HIGH TACK ADHESIVE & SEALANT

PRODUCT

Dekasyll MS-5 is a MS Polymer based adhesive with a high green strength and is suitable for making elastic constructive joints. Due to its high green strength clamping times can often be reduced or clamps are not needed anymore. **Dekasyll MS-5** can also be used as sealant, if similar material (similar stiffnesses) are joined together, or if mechanical fastening methods are used.

APPLICATIONS

- Elastic bondings and sealings in e.g. bus-, train-, caravan-, camper and truck construction.
- Bonding of windows in e.g. busses and trains.
- Bonding of corner profiles of aluminium or polyester on trailers.
- Bonding of polyester parts on metal frames.

FEATURES

- Solvent-, isocyanate- and PVC free.
- Very good UV-resistance and ageing properties.
- In general good adhesion on several substrates without the use of a primer.
- Permanent elastic within temperatures from -40°C till $+120^{\circ}\text{C}$.
- Neutral, odourless and fast curing.
- Paintable after skin forming (wet on wet); this will in general not influence the curing speed.
- Paint compatible with most industrial paint- or lacquer systems, both alkyd resin and dispersion based (due to the large scale of different types of industrial paints a paint compatibility test is recommended!)

ADHESION

In general **Dekasyll MS-5** adheres well without primer on clean, dry, dust- and grease free substrates of aluminium, stainless steel, galvanised steel, zinc, copper, brass, powder coated metal, most lacquered metal surfaces, glass, PVC, polyester (GRP), painted and lacquered wood, etc. No adhesion on untreated polyethylene, polypropylene and teflon. In those cases where due to great thermal or physical loads, especially under wet conditions, high adhesion demands are needed, the use of an adhesion promotor is recommended. For not mentioned substrates and additional information consult Dekalin.

METHOD OF USE

Dekasyll MS-5 can easily be extruded with a hand- or air pressure gun at temperatures between $+5^{\circ}\text{C}$ and 35°C . In sealing applications **Dekasyll MS-5** should be tooled or smoothed within 12 minutes (at $20^{\circ}\text{C}/50\% \text{R.H.}$) with a spatula or putty knife, occasionally moistened with a mild soap solution. Avoid soap solution penetrating between joint sides and sealant, because this will create loss of adhesion. In bonding applications the substrates have to be assembled within 15 minutes (at $20^{\circ}\text{C}/50\% \text{R.H.}$) after applying **Dekasyll MS-5**. The higher the temperature, the shorter the open time will be! In general an adhesive thickness of 2 mm is recommended if similar materials (similar stiffnesses) are bonded. The larger the difference in thermal expansion is, the thicker the adhesive bead should be. For more details Dekalin should be consulted. At a temperature of 20°C and a relative humidity of 50% **Dekasyll MS-5** can be painted with the most industrial paints already 10 minutes after application. Best adhesion of paint coats is generally obtained if painted within 4 hours after applying **Dekasyll MS-5**. Cleaning tools or removing uncured residue of Dekasyll MS-2 can be done with a clean colourless cloth, wetted with e.g. acetone or MEK. It is recommended to make a trial first to check possible attack of the substrate by these cleaners.

WWW.DEKALIN.COM



HIGH QUALITY PRODUCTS FOR MOTORHOME, CARAVAN AND TRAILER TENT

TECHNICAL DATA SHEET

TECHNICAL DATA

Basic material	: MS Polymer
Curing method	: moisture
Specific density (20°C)	: ca. 1.4 kg/liter
Skin forming time (20°C/50% R.H.)	: ca. 12 min.
Open time (20°C/50%R.H.)	: < 15 min.
Curing speed after 24 hrs (20°C/50%R.H.)	: ca. 4 mm
Shore A hardness (DIN 53505)	: ca. 55
Volume change (DIN 52451)	: < 3%
Green strength (Physica Rheometer MC100) (max. load which can be applied per m ² uncured adhesive without sagging)	: ca. 700 Pa
Tensile stress (100%) (DIN 53504/ISO 37)	: ca. 1.7 MPa
Tensile stress at break (DIN 53504/ISO 37)	: ca. 2.8 MPa
Elongation at break (DIN 53504/ISO 37)	: ca. 210%
Shear stress (DIN 53283/ASTM D1002) (Alu-Alu; adh. thickness 2mm; test speed 50 mm/min.)	: ca. 2.5 MPa
Tear propagation (DIN 53515/ISO 34) (Type C, test speed 500 mm/min.)	: ca. 14 N/mm
Solvent percentage	: 0%
Isocyanate percentage	: 0%
Temperature resistance	: - 40°C till +120°C
Temperature resistance (max. 20 minutes)	: +180°C
Application temperature	: +5°C till +35°C
UV- and weather resistance	: excellent
Colours (standard)	: white, black
Packaging	: 290 ml cartridges, 600 ml bags, other packaging on request.

STORAGE STABILITY

Dekasyll MS-5 may be stored for 12 months in a closed (unopened) packaging in a dry place at temperatures between +5°C and +30°C (cartridges 18 months).

SAFETY PRECAUTIONS

No specific safety precautions required. Consult safety data sheet.

TRANSPORT CLASSIFICATION

Not applicable.

©Dekalin November, 2013

Dekalin, brand of Diffutherm B.V.
Smaragdweg 50
NL-5527 LB Hapert

Tel. +31 (0)497 551 080
Fax +31 (0)497 551 088

E-mail: info@dekalin.nl
Internet: www.dekalin.com

All figures, recommendations and safety precautions are based on thorough investigations and our actual experience and are without engagement. Although the documentation has been set up with most carefulness, we do not accept any responsibility for mistakes, inaccuracies or printer's errors. We reserve the right to adjust the product, whenever we feel necessary. Because the design, the quality of the substrate and the conditions during application fall beyond our control, no responsibility for executed works can be accepted on the basis of this documentation. We therefore recommend to carry out own tests on the spot. All our deliveries are subject to the General Terms and Conditions of Sale and Purchase of Diffutherm B.V.



13 Operating Instructions CAP 950

**The operating instructions for the
CAP 950
starts from this page**

If, despite studying these operating instructions, you still have questions about getting started with the unit or using it correctly, or if unexpected problems occur, please contact your specialist dealer.

The Kathrein Technical Customer Support is also at your disposal at +49 731 27090970.

13.1 Safety Instructions and General Guidelines

In the following operating manual we assume that the CAP converter and the turntable have been properly installed and connected, as described in Chapter 4, p. 7 and Chapter 5, p. 12. If you have not yet done so, read the safety instructions at the beginning of this manual and follow them when handling the CAP converter and the turntable!

Tip Before setting up your satellite system, make sure that the location allows a free view to the satellite positions to the south and is not shadowed by trees or other obstructions.



NOTICE

Risk of malfunction and material damage from:

Overheating of the turntable motor!

If the turntable motor operates without interruption for longer than 20 minutes, it can cause overheating of the motor. None of the automatically initiated search procedures require as much as 20 minutes. Only repeated unsuccessful search procedures or manual overrides by the user can cause this limit to be exceeded.

► Do not let the turntable motor continuously run for longer than 20 minutes.

Absence of the ignition signal!

As soon as the ignition signal is no longer present at the turntable, it may automatically move to the last known satellite position. Requirement: The receiver is switched on and the turntable is supplied with a +12 V power supply.

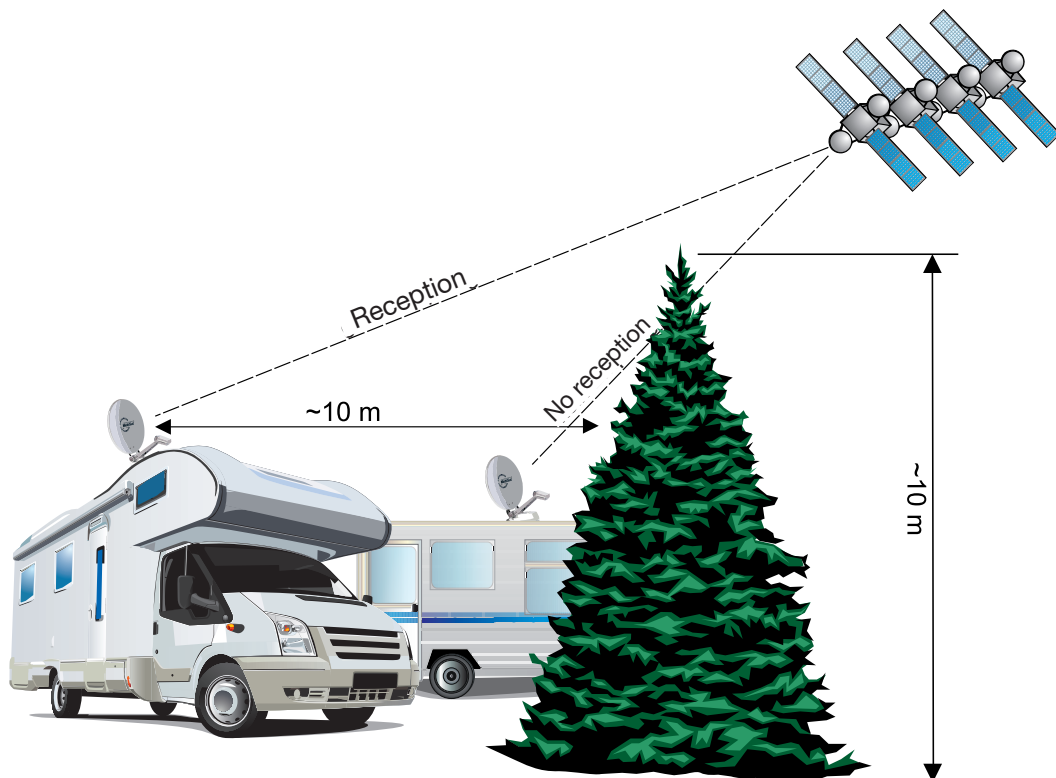

13.2 Installing the CAP Converter

✓ The master coaxial cable is connected to the *IF INPUT* ② socket; see 5.2.6, p. 25.

1. Using the coaxial cable¹⁾, connect the TV to the *IF OUTPUT* ① socket.



NOTICE

Risk of material damage!

► Do not interchange the cables.

2. Make sure that the supplied 12 V connection cable is installed by a specialist dealer.

¹⁾ Not included in the scope of delivery

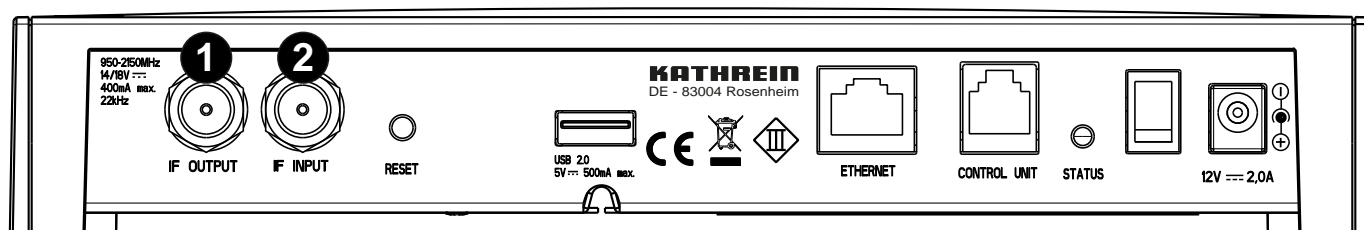

13.3 Change of Location

To speed up the search after a change of location, enter the new location in the CAPcontrol app¹⁾ or in the external operating unit²⁾.

^{1) 2)} Available as an accessory

13.4 Operating the Turntable Using the External Push-button

13.4.1 Starting the Turntable

- ✓ The turntable is in the park position.
- ▶ Press the push-button.
 - ⇒ The turntable moves to the last satellite position.

13.4.2 Moving the Turntable to the Park Position

- ✓ The turntable is extended.
- ▶ Press the push-button.
 - ⇒ The turntable lowers to the park position.

13.4.3 Resetting the CAP System

- ▶ Press the push-button for 5 seconds.
 - ⇒ The CAP system is being reset. The LED flashes 3 x green and 1 x red until the CAP system is in the park position.

13.5 Updating Software and Channel List

13.5.1 Updating the Channel List

- ✓ An FAT 32 formatted USB storage device is available.
- 1. On the USB, create a *kathrein* folder with a *capconverter* subfolder.
- 2. Download a *channel.xml* file with an up-to-date channel list from www.kathrein.com ▶ [Service](#).
- 3. Save the *channel.xml* file on the USB in the *capconverter* subfolder.
- 4. Connect the USB to the CAP converter.
- 5. Switch off the CAP converter using the on/off switch.
- 6. Switch the CAP converter back on.
 - ⇒ The channel list is loaded when the CAP converter starts. The LED status shows whether the channel list has been successfully downloaded or whether there has been a problem, see *LED Status Indicator on the CAP Converter/ External Push-button*, p. 48.

13.5.2 Updating Software

- ✓ An FAT 32 formatted USB storage device is available.
- 1. On the USB, create a *kathrein* folder with a *capconverter* subfolder.
- 2. Download a *CAP950-Vq.xx_Bxx.bin* file with the up-to-date software from www.kathrein.com ▶ [Service](#).
- 3. Save the *CAP950-Vq.xx_Bxx.bin* file on the USB in the *capconverter* subfolder.
- 4. Connect the USB to the CAP converter.
- 5. Switch off the CAP converter using the on/off switch.
- 6. Press the push-button and simultaneously switch the CAP converter using the on/off switch back on.
 - ⇒ The software is loaded when the CAP converter starts. The LED status shows whether the software has been successfully downloaded or whether there has been a problem, see *LED Status Indicator on the CAP Converter/ External Push-button*, p. 48.



It is only possible to perform the update if the switch on the rear side of the CAP converter is pressed!

13.6 LED Status Indicator on the CAP Converter/ External Push-button

Function	LED colour	Signal	Description
Error	Red	LED flashes 1 x for 0.5 second, then stops for 2 seconds	No connection to CAP
		LED flashes 2 x for 0.5 second, then stops for 2 seconds	Satellite not found
		LED flashes 3 x for 0.5 second, then stops for 2 seconds	Ignition is active
		LED flashes 4 x for 0.5 second, then stops for 2 seconds	CAP is blocked
		LED flashes 5 x for 0.5 second, then stops for 2 seconds	Operating voltage too low
		LED flashes 6 x for 0.5 second, then stops for 2 seconds	Temperature warning
		LED flashes 7 x for 0.5 second, then stops for 2 seconds	Transponder does not exist



To return the CAP converter to the normal operation:

1. Check the cause of error.
2. Press the push-button once to acknowledge the error in order for the CAP converter to operate normally again.

Normal operation	Green	LED flashes slowly	CAP is in the park position
		LED flashes 3 x, then stops for a bit	CAP is moving to a position, e.g. to the park position
		LED flashes quickly	CAP searches for a satellite position
		LED is permanently on	Satellite is found
	Red	LED is permanently on	Standby

USB Update	Yellow ¹⁾	LED is permanently on	Downloading file from USB
	Green	LED is lit green for 1 second	Download successful
	Red	LED is lit red for 1 second	Failed to download the file
	Yellow ¹⁾	LED is lit yellow for 1 second	Download complete

Boot-loader	Yellow ¹⁾	LED is permanently on	Bootloader is active
	Red	LED flashes 1 x for 0.5 second, then stops for 2 seconds	Data carrier not found
		LED flashes 2 x for 0.5 second, then stops for 2 seconds	Folder structure/Update file not found
		LED flashes 3 x for 0.5 second, then stops for 2 seconds	Invalid update file
		LED flashes 4 x for 0.5 second, then stops for 2 seconds	File saving failed

¹⁾ On the external push-button, the red and the green LEDs are on at the same time

14 Waste Disposal



Electronic equipment

Electronic equipment is not domestic waste – in accordance with directive 2002/96/EC OF THE EUROPEAN PARLIAMENT AND THE COUNCIL dated 27th January 2003 concerning used electrical and electronic appliances, it must be disposed of properly. At the end of its service life, take this unit for disposal at a designated public collection point.

Spent batteries

Do not throw spent batteries into your domestic waste; take them to a collection point for used batteries.

15 Declaration of Conformity



EG-Konformitätserklärung / Declaration of Conformity

Hersteller / Manufacturer: **Kathrein-Werke KG**
Anschrift / Address: **Postfach 10 04 44
83004 Rosenheim**
Produktbezeichnung / Product: **MobiSet 2, 3, 4**
Typenbezeichnung / Type: **CAP 650, CAP 750, CAP 950**
Bestellnummer / Article number: **20310030, 20310031, 20310032**

Die **Kathrein-Werke KG** bestätigt hiermit, dass das bezeichnete Produkt mit den folgenden Richtlinien zur Angleichung der Rechtsvorschriften übereinstimmt.
*The **Kathrein-Werke KG** hereby confirm that the designated product complies with the following directives on the harmonisation of the laws.*

- Elektromagnetische Verträglichkeit / EMC (2004/108/EC vom 15.12.2004)
Folgende Normen werden eingehalten / *Applied harmonised standards:*
EN 55013: 2001 + A1: 2003 + A2: 2006, EN 55020: 2007 + A11: 2011
EN 61000-3-2: 2006 + A1: 2009 + A2: 2009, EN 61000-3-3: 2008
EN 50498: 2010
- Maschinenrichtlinie(2006/42/EG):
EN ISO 12100-1: 2003, EN ISO 12100-2: 2003,
EN ISO 13857: 2008, EN 349: 1993 + A1: 2008
- RoHS (2011/65/EU vom 08.06.2011)
Folgende Normen werden eingehalten / *Applied harmonised standards:*
EN 50581: 2012

Entwicklung, Produktion, Qualitätssicherung und Vertrieb basieren auf der Norm EN ISO 9001.
Development, production, quality assurance and marketing are based on the standard EN ISO 9001.

Ort, Datum: Rosenheim, den 26.11.2015
Place, Date:

Rechtsverbindliche Unterschrift:
Binding signature:

ppa.

A handwritten signature in black ink, appearing to read 'W. Staniszewski', written over a horizontal dashed line.

W. Staniszewski

